

INTRODUCTION

Trades workers use fractions all the time to measure materials and read blueprints.

When you have completed this section you will be able to:

- Change improper fractions to mixed numbers and mixed numbers to improper fractions.
- Choose a common denominator.
- Express fractions in lowest terms.
- Multiply and divide fractions.
- Add and subtract fractions.
- Solve word problems using fractions.
- Solve applications using fractions.

DEFINING FRACTIONS

The following definitions will help you to understand and to use fractions better.

Whole Number: Whole numbers are used to count things.
Examples: 1, 2, 3, 4, and so on.

Fraction: A fraction is a ratio of two numbers written with an oblique or horizontal bar.

Example: $1/2$ or $\frac{1}{2}$

1 ← numerator, the number of parts
2 ← denominator, the whole amount

The numbers 1 and 2 in the fraction are called terms.

Proper Fraction: A proper fraction is a part of a whole. It is less than one. The numerator (top) is smaller than the denominator (bottom).

Example: $\frac{1}{2}, \frac{7}{8}, \frac{3}{4}$

Improper Fraction: An improper fraction has a numerator that is bigger than its denominator. An improper fraction has a value equal to or greater than one.

Example: $\frac{9}{8}, \frac{14}{4}, \frac{8}{7}, \frac{3}{2}$

Mixed Numbers: A mixed number is a combination of a whole number and a fraction.

Example: $2\frac{1}{4}, 5\frac{1}{3}, 3\frac{7}{8}$

Equivalent Fraction: Equivalent fractions are fractions that have the same value.

Example: $\frac{1}{4} = \frac{2}{8} = \frac{4}{16}$

Lowest Term: The lowest term means reducing the fraction to the lowest equivalent fraction.

Example: $\frac{2}{4} = \frac{1}{2}, \frac{2}{8} = \frac{1}{4}$

Write whole number, proper fraction, improper fraction or mixed number beside each of the following.

1) $\frac{1}{2}$

2) $3\frac{1}{4}$

3) $\frac{3}{2}$

4) 7

5) $\frac{1}{4}$

6) $2\frac{1}{16}$

7) $\frac{7}{8}$

8) $\frac{13}{8}$

9) $\frac{2}{1}$

10) 16

11) $\frac{12}{16}$

12) $\frac{1}{4}$

13) $1\frac{1}{4}$

14) $\frac{5}{4}$

15) $\frac{9}{8}$

16) $1\frac{1}{8}$

WRITING FRACTIONS

numerator $\leftarrow \frac{1}{\rightarrow}$ number of pieces you are counting
 denominator $\leftarrow \frac{\quad}{2} \rightarrow$ the name of the whole

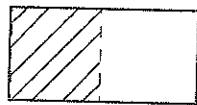

$\frac{1}{2}$

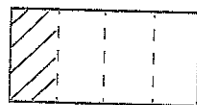

$\frac{1}{4}$

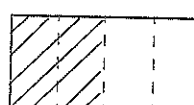

$\frac{2}{4}$

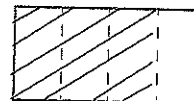

$\frac{3}{4}$



$\frac{2}{8}$

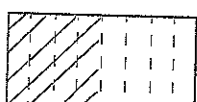

$\frac{1}{4}$

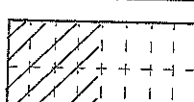

$\frac{4}{8}$

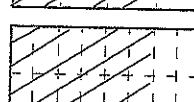

$\frac{4}{16}$

Write the fraction that represents the shaded portion of each of the following sheets of plywood:

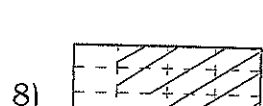
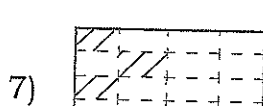
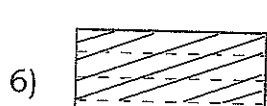
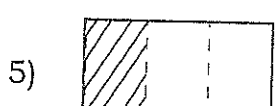
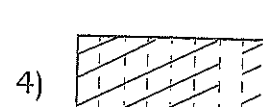
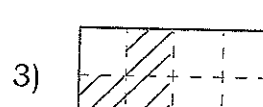
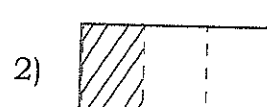
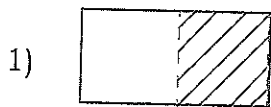

CHANGING IMPROPER FRACTIONS TO MIXED NUMBERS

Improper fractions should always be changed to whole or mixed numbers.

Step 1: Divide the numerator by the denominator.

Step 2: Write the remainder over the denominator.

Step 3: Write the whole number beside the fraction.

Step 4: Express fractions in lowest terms.

Example 1:

Change $\frac{34}{8}$ to a whole or mixed number.

$$\begin{array}{r} 4 \\ 8 \overline{)34} \\ \underline{32} \\ 2 \end{array}$$

There is a remainder.
Write the remainder
over the denominator.

$$\frac{34}{8} = 4 \frac{2}{8} = 4 \frac{1}{4}$$

Reduce fraction
to lowest
terms.

Example 2:

Change $\frac{12}{4}$ to a whole or mixed number.

$$\begin{array}{r} 3 \\ 4 \overline{)12} \\ \underline{12} \\ 0 \end{array}$$

There is no remainder.

$$\frac{12}{4} = 3$$

Change the following improper fractions to whole or mixed numbers.

1) $\frac{4}{2}$

2) $\frac{10}{8}$

3) $\frac{8}{4}$

4) $\frac{15}{5}$

5) $\frac{4}{3}$

6) $\frac{10}{4}$

7) $\frac{3}{2}$

8) $\frac{5}{2}$

9) $\frac{13}{8}$

10) $\frac{21}{3}$

11) $\frac{7}{4}$

12) $\frac{9}{3}$

13) $\frac{5}{4}$

14) $\frac{7}{2}$

15) $\frac{17}{16}$

16) $\frac{21}{16}$

CHANGING MIXED NUMBERS TO IMPROPER FRACTIONS

When you multiply and divide fractions, you need to change mixed numbers to improper fractions.

Step 1: Multiply the whole number by the denominator.

Step 2: Add the numerator.

Step 3: Write the total over the denominator.

Example 1:

Change $2\frac{3}{8}$ to an improper fraction.

$$2 \rightarrow \times \frac{3}{8} \rightarrow + = \frac{19}{8}$$

CHANGING A WHOLE NUMBER TO AN IMPROPER FRACTION

Example:

Place the whole number over 1. $3 = \frac{3}{1}$

Change the following mixed numbers to improper fractions.

1) $1\frac{1}{2}$

2) $1\frac{1}{3}$

3) $2\frac{1}{4}$

4) $3\frac{1}{8}$

5) 4

6) $7\frac{1}{2}$

7) $3\frac{3}{4}$

8) $6\frac{3}{16}$

9) 11

10) $9\frac{11}{16}$

11) $4\frac{5}{8}$

12) $3\frac{3}{8}$

13) $2\frac{1}{8}$

14) $9\frac{1}{3}$

15) 21

16) $6\frac{7}{8}$

Remember:

You multiply the numerator and the denominator by the same number.

COMMON DENOMINATORS

When you add and subtract fractions, the fractions must have a common denominator. This means all fractions in the problem have the same denominator. A common denominator is a number that can be divided into evenly by all the denominators in the problem. The smallest number that can be used as the denominator is called the lowest common denominator (LCD).

Step 1: Multiply the numerator and the denominator by the same number.

Example 1:

$$\frac{1}{2} =$$

$$\frac{1 \times 2}{2 \times 2} = \frac{2}{4}$$

$$\frac{1}{2} = \frac{2}{4}$$

Multiply the numerator and the denominator by the same number.

These are equivalent fractions.

Example 2:

$$\frac{1}{4} =$$

$$\frac{1 \times 4}{4 \times 4} = \frac{4}{16}$$

$$\frac{1}{4} = \frac{4}{16}$$

Multiply the numerator and the denominator by the same number.

These are equivalent fractions.

Show the following pairs of fractions are equivalent fractions by dividing up the sheets of plywood.

1) $\frac{3}{4} = \frac{6}{8}$



2) $\frac{1}{2} = \frac{4}{8}$



3) $\frac{1}{3} = \frac{2}{6}$



4) $\frac{1}{4} = \frac{2}{8}$



5) $\frac{3}{4} = \frac{12}{16}$



Find the LCD for the following pairs of fractions.

1) $\frac{1}{4}, \frac{1}{2}$

2) $\frac{1}{8}, \frac{1}{4}$

3) $\frac{1}{3}, \frac{1}{12}$

4) $\frac{3}{8}, \frac{5}{16}$

5) $\frac{1}{5}, \frac{1}{2}$

6) $\frac{3}{4}, \frac{7}{8}$

7) $\frac{1}{2}, \frac{1}{3}$

8) $\frac{1}{12}, \frac{1}{8}$

9) $\frac{2}{3}, \frac{3}{4}$

10) $\frac{5}{8}, \frac{7}{16}$

11) $\frac{3}{4}, \frac{2}{5}$

12) $\frac{1}{20}, \frac{3}{5}$

13) $\frac{5}{8}, \frac{1}{2}$

14) $\frac{3}{4}, \frac{11}{16}$

15) $\frac{2}{6}, \frac{3}{8}$

16) $\frac{3}{8}, \frac{15}{16}$

MULTIPLYING FRACTIONS

MULTIPLYING FRACTIONS

Hint:
The denominator
for any whole
number is one.
 $4 = \frac{4}{1}$ $8 = \frac{8}{1}$

Step 1: Change all mixed numbers and whole numbers to improper fractions.

Step 2: Multiply the numerators.
Multiply the denominators.

Step 3: Change improper fractions to mixed numbers.
Reduce fractions to lowest terms.

Example 1:

$$\frac{1}{2} \times \frac{1}{2} = \frac{1}{4}$$

There are no mixed numbers.
Multiply the numerators.
Multiply the denominators.

Example 2:

$$1\frac{1}{2} \times 2\frac{1}{4} =$$

$$\frac{3}{2} \times \frac{9}{4} =$$

$$\frac{27}{8} = 3\frac{3}{8}$$

Change mixed numbers to improper fractions.
Multiply the numerators.
Multiply the denominators.

Change improper fractions to mixed fractions.

Multiply the following.

1) $\frac{1}{4} \times \frac{1}{3}$

2) $\frac{2}{5} \times \frac{1}{3}$

3) $\frac{1}{4} \times \frac{2}{3}$

4) $\frac{7}{8} \times \frac{1}{5}$

5) $2 \times \frac{1}{4}$

6) $5 \times \frac{1}{3}$

7) $\frac{1}{2} \times 9$

8) $\frac{2}{3} \times 4$

9) $1\frac{2}{3} \times 4$

10) $2\frac{4}{5} \times 3$

11) $2 \times 9\frac{1}{4}$

12) $2 \times 1\frac{3}{4}$

13) $3\frac{1}{3} \times 1\frac{1}{8}$

14) $1\frac{5}{8} \times 3\frac{1}{4}$

15) $1\frac{1}{8} \times 1\frac{1}{4}$

16) $2\frac{1}{2} \times 4\frac{1}{8}$

17) $6\frac{2}{3} \times 1\frac{1}{4}$

18) $1\frac{1}{2} \times 3\frac{1}{2}$

19) $7\frac{1}{8} \times 4\frac{1}{4}$

20) $3\frac{3}{16} \times 2\frac{1}{2}$

DIVIDING FRACTIONS

INVERTING FRACTIONS

Example:

$\frac{8}{5}$ is called the inverse or reciprocal of $\frac{5}{8}$.

$\frac{4}{3}$ is called the inverse or reciprocal of $\frac{3}{4}$.

INVERTING MIXED NUMBERS AND WHOLE NUMBERS

Step 1: Change mixed or whole numbers to improper fractions.

Step 2: Invert the proper fraction.

Example:

$2\frac{1}{4} = \frac{9}{4}$ The inverse of $\frac{9}{4}$ is $\frac{4}{9}$.

$7 = \frac{7}{1}$ The inverse of $\frac{7}{1}$ is $\frac{1}{7}$.

Write the inverse of the following.

1) $\frac{7}{8}$

2) $\frac{3}{4}$

3) $\frac{2}{1}$

4) $\frac{2}{3}$

5) $\frac{9}{2}$

6) $\frac{7}{4}$

7) $\frac{3}{8}$

8) $\frac{5}{8}$

9) $1\frac{1}{2}$

10) $2\frac{3}{16}$

11) $6\frac{5}{8}$

12) $3\frac{3}{4}$

13) $5\frac{1}{4}$

14) $8\frac{9}{16}$

15) $4\frac{3}{4}$

16) $7\frac{1}{2}$

DIVIDING FRACTIONS

- Step 1: Change all mixed numbers and whole numbers to improper fractions.
- Step 2: Change the division sign to a multiplication sign. Invert the second fraction.
- Step 3: Multiply the numerator by the numerator. Multiply the denominator by the denominator.
- Step 4: Change improper fractions to mixed numbers or whole numbers. Express fractions in lowest terms.

Example 1:

$$\frac{1}{2} \div \frac{1}{4} =$$

There are no mixed numbers.

$$\frac{1}{2} \times \frac{4}{1} =$$

Change the division sign to a multiplication sign. Invert the second fraction.

$$\frac{1}{2} \times \frac{4}{1} = \frac{4}{2}$$

Multiply the numerator by the numerator. Multiply the denominator by the denominator.

$$\frac{4}{2} = 2$$

Change improper fractions to mixed numbers or whole numbers.

Example 2:

$$2\frac{1}{2} \div 1\frac{1}{4} = \frac{5}{2} \div \frac{5}{4} =$$

Change mixed numbers and whole numbers to improper fractions.

$$\frac{5}{2} \times \frac{4}{5} =$$

Change the division sign to a multiplication sign. Invert the second fraction.

$$\frac{5}{2} \times \frac{4}{5} = \frac{20}{10}$$

Multiply the numerator by the numerator. Multiply the denominator by the denominator.

$$\frac{20}{10} = 2$$

Change improper fractions to mixed numbers or whole numbers.

Divide the following.

1) $\frac{1}{3} \div \frac{1}{2}$

2) $\frac{2}{5} \div \frac{1}{2}$

3) $\frac{1}{4} \div \frac{1}{3}$

4) $\frac{2}{3} \div \frac{3}{4}$

5) $\frac{3}{7} \div \frac{4}{9}$

6) $\frac{2}{11} \div \frac{5}{8}$

7) $\frac{1}{3} \div \frac{2}{3}$

8) $\frac{5}{16} \div \frac{2}{3}$

9) $7\frac{1}{2} \div \frac{1}{3}$

10) $6 \div \frac{2}{3}$

11) $3 \div \frac{7}{4}$

12) $\frac{2}{3} \div 4$

13) $\frac{1}{16} \div 1\frac{1}{8}$

14) $2\frac{2}{3} \div 4$

15) $1\frac{1}{5} \div 3$

16) $2\frac{3}{8} \div 1$

17) $7\frac{1}{2} \div 3\frac{1}{2}$

18) $1\frac{1}{4} \div 2\frac{3}{8}$

19) $1\frac{1}{8} \div 2\frac{2}{8}$

20) $2\frac{5}{8} \div 2\frac{3}{8}$

ADDING FRACTIONS

Remember:

Do not change mixed numbers to improper fractions when you are adding or subtracting fractions.

- Step 1:** Determine the common denominator.
Do not change mixed numbers or whole numbers to improper fractions.
- Step 2:** Add the numerators and place the answer over the denominator. Do not add the denominators.
Add the whole numbers.
- Step 3:** Express fractions in lowest terms.

Example 1:

$$\frac{1}{4} + \frac{1}{4} = \frac{2}{4}$$

$$\frac{2}{4} = \frac{1}{2}$$

There is already a common denominator.
Add the numerators and place the answer over the denominator.

Express fractions in lowest terms.

Example 2:

$$\frac{1}{2} + \frac{3}{8} =$$

$$\frac{1 \times 4}{2 \times 4} = \frac{4}{8}$$

$$\frac{4}{8} + \frac{3}{8} = \frac{7}{8}$$

$$\frac{7}{8}$$

Determine the common denominator.
The lowest common denominator (LCD) for 2 and 8 is 8.

Change $\frac{1}{2}$ to eighths. Multiply the numerator and the denominator by 4.

Add the numerators. Do not add the denominators.

Express fractions in lowest terms.
Seven-eighths cannot be reduced.

Example 3:

$$1 \frac{3}{4} + 2 \frac{5}{8} =$$

$$1 \frac{3 \times 2}{4 \times 2} = 1 \frac{6}{8}$$

$$1 \frac{6}{8} + 2 \frac{5}{8} = 3 \frac{11}{8}$$

$$3 \frac{11}{8} = 4 \frac{3}{8}$$

Determine the common denominator.

The LCD for 4 and 8 is 8.

Add the numerators and place the answer over the denominator. Do not add the denominators. Add the whole numbers.

Express fractions in lowest terms.

Example 4:

$$1\frac{2}{3} + 3\frac{3}{4} =$$

Determine the common denominator.

$$1\frac{2 \times 4}{3 \times 4} = 1\frac{8}{12}$$

The LCD for 3 and 4 is 12.

$$3\frac{3 \times 3}{4 \times 3} = 3\frac{9}{12}$$

Add the numerators and place the answer over the denominator. Do not add the denominators. Add the whole numbers.

$$1\frac{8}{12} + 3\frac{9}{12} = 4\frac{17}{12}$$

Express fractions in lowest terms.

$$4\frac{17}{12} = 5\frac{5}{12}$$

Add the following.

1) $\frac{1}{4} + \frac{2}{4}$

2) $\frac{1}{4} + \frac{3}{4}$

3) $\frac{3}{8} + \frac{1}{8}$

4) $\frac{5}{8} + \frac{7}{8}$

5) $\frac{1}{2} + \frac{1}{4}$

6) $\frac{1}{2} + \frac{1}{8}$

7) $\frac{3}{6} + \frac{2}{6}$

8) $\frac{1}{4} + \frac{3}{8}$

9) $\frac{5}{8} + \frac{13}{16}$

10) $\frac{5}{6} + \frac{1}{4}$

11) $\frac{1}{4} + \frac{7}{8}$

12) $\frac{5}{16} + \frac{3}{4}$

13) $7\frac{1}{8} + 6\frac{1}{8}$

14) $6\frac{1}{8} + 4\frac{3}{16}$

15) $2\frac{1}{2} + 1\frac{1}{4}$

16) $5\frac{1}{3} + 7\frac{1}{6}$

17) $3 + 7\frac{1}{8} + 5\frac{5}{8}$

18) $2\frac{1}{16} + 3\frac{1}{8} + 7\frac{7}{16}$

19) $2\frac{1}{4} + 4\frac{1}{2} + 5\frac{7}{16}$

20) $3\frac{1}{4} + 9\frac{3}{8} + 1\frac{3}{4}$

SUBTRACTING FRACTIONS

- Step 1: Determine the common denominator. Do not change mixed numbers or whole numbers to improper fractions.
- Step 2: Subtract the numerators and place the answer over the denominator. Do not subtract the denominators. Subtract the whole numbers.
- Step 3: Express fractions in lowest terms.

Example 1:

$$\frac{3}{4} - \frac{1}{4} = \frac{2}{4}$$

$$\frac{2}{4} = \frac{1}{2}$$

There is already a common denominator. Subtract the numerators and place the answer over the denominator.

Express fractions in lowest terms.

Example 2:

$$\frac{3}{4} - \frac{5}{8} =$$

$$\frac{3 \times 2}{4 \times 2} = \frac{6}{8}$$

$$\frac{6}{8} - \frac{5}{8} = \frac{1}{8}$$

$$\frac{1}{8}$$

Determine the common denominator.

The LCD for 4 and 8 is 8.

Subtract the numerators and place the answer over the denominator. Do not subtract the denominators.

Express fractions in lowest terms. $\frac{1}{8}$ is the lowest term.

Example 3:

$$4 \frac{5}{8} - 2 \frac{3}{16} =$$

$$4 \frac{5 \times 2}{8 \times 2} = 4 \frac{10}{16}$$

$$4 \frac{10}{16} - 2 \frac{3}{16} = 2 \frac{7}{16}$$

$$2 \frac{7}{16}$$

Determine the common denominator.

The LCD for 8 and 16 is 16.

Subtract the numerators and place the answer over the denominator. Do not subtract the denominators. Subtract the whole numbers.

Express fractions in lowest terms. $2 \frac{7}{16}$ is the lowest term.

Example 4:

Sometimes when you subtract fractions you have to borrow just like with whole numbers.

$$7 \frac{1}{4} - 1 \frac{3}{4} =$$

There is already a common denominator.
 $\frac{3}{4}$ is bigger than $\frac{1}{4}$.
 You have to borrow from 7.

$$7 \frac{1}{4} = 6 \frac{5}{4}$$

Borrow 1 from 7 and change the 7 to 6.
 Change the borrowed 1 to fourths.
 $1 = \frac{4}{4}$. Add $\frac{4}{4}$ to $\frac{1}{4}$.

$$6 \frac{5}{4} - 1 \frac{3}{4} = 5 \frac{2}{4}$$

Subtract the numerators and place the answer over the denominator.
 Do not subtract the denominators. Subtract the whole numbers.

$$5 \frac{2}{4} = 5 \frac{1}{2}$$

Express fractions in lowest terms.

Example 5:

$$5 \frac{3}{8} - 1 \frac{3}{4} =$$

Determine the common denominator.

$$1 \frac{3 \times 2}{4 \times 2} = 1 \frac{6}{8}$$

The LCD for 8 and 4 is 8.

$$5 \frac{3}{8} - 1 \frac{6}{8} =$$

$\frac{6}{8}$ is bigger than $\frac{3}{8}$.

You have to borrow from 5.

$$5 \frac{3}{8} = 4 \frac{11}{8}$$

Borrow 1 from 5 and change the five to 4.
 Change the borrowed 1 to eighths.

$1 = \frac{8}{8}$. Add $\frac{8}{8}$ to $\frac{3}{8}$.

$$4 \frac{11}{8} - 1 \frac{6}{8} = 3 \frac{5}{8}$$

Subtract the numerators and place the answer over the denominator. Do not subtract the denominators. Subtract the whole numbers.

$$3 \frac{5}{8}$$

Express fractions in lowest terms.

$3 \frac{5}{8}$ is the lowest term.

Subtract the following.

1) $\frac{3}{4} - \frac{1}{4}$

2) $\frac{3}{8} - \frac{1}{8}$

3) $\frac{15}{16} - \frac{7}{16}$

4) $\frac{7}{8} - \frac{3}{8}$

5) $\frac{3}{4} - \frac{1}{2}$

6) $\frac{1}{2} - \frac{1}{3}$

7) $\frac{3}{8} - \frac{1}{4}$

8) $\frac{11}{16} - \frac{3}{8}$

9) $4\frac{7}{8} - 2\frac{2}{8}$

10) $5\frac{5}{8} - 1\frac{5}{16}$

11) $3\frac{2}{3} - 1\frac{1}{2}$

12) $4\frac{3}{8} - 1\frac{1}{4}$

13) $3\frac{1}{4} - 1\frac{3}{4}$

14) $12\frac{8}{8} - 5\frac{5}{8}$

15) $2\frac{1}{4} - 1\frac{1}{2}$

16) $2\frac{1}{2} - \frac{3}{4}$

17) $5 - 1\frac{3}{4}$

18) $1 - \frac{5}{8}$

19) $7 - \frac{15}{16}$

20) $6 - 4\frac{1}{8}$

21) $7\frac{5}{8} - 2\frac{3}{4}$

22) $15\frac{1}{4} - 13\frac{5}{16}$

23) $2\frac{1}{5} - 1\frac{1}{10}$

24) $3\frac{5}{8} - 1\frac{3}{4}$

PRACTICE

- 1) A carpenter takes one day to complete $\frac{1}{2}$ a set of cabinets. What fraction is complete in $\frac{1}{4}$ of a day?

- 2) A sheet of drywall is cut into quarters. Each quarter is cut into thirds. What fraction of a whole sheet is each of these small pieces?

- 3) A chopping block was made by gluing boards $3\frac{1}{4}$ " , $6\frac{1}{8}$ " and $2\frac{5}{16}$ " wide together. What is the total width of the chopping block?

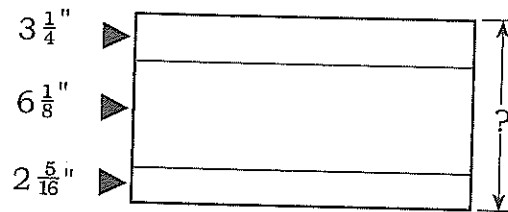

- 4) It takes $4\frac{1}{4}$ sheets of 8' long plywood laid out end to end to cover a roof. How long is the roof?

- 5) A trades worker uses $1\frac{1}{2}$ " stock to temporarily shim up a heavy beam. One shim is $1\frac{1}{2}$ " thick. How many shims or pieces must the carpenter use to lift the beam $7\frac{1}{2}$ "?

Remember:

Always reduce fractions to the lowest terms.

- 6) $\frac{5}{8}$ " plywood is nailed to $9\frac{1}{4}$ " joists that rest on a beam that is $11\frac{3}{8}$ " deep. What is the total distance from the bottom of the beam to the top of the plywood flooring?

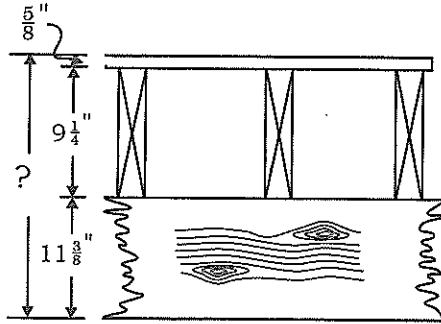

Use the drawing below to answer the next 4 questions.

- 7) What does distance A equal?

distance A is _____

- 8) What does distance B equal?

distance B is _____

- 9) What does distance C equal?

distance C is _____

- 10) What does distance D equal?

distance D is _____

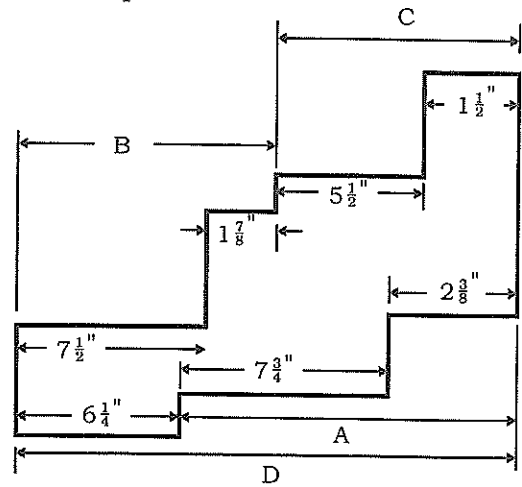

- 11) Calculate the missing dimension in the drawing below.

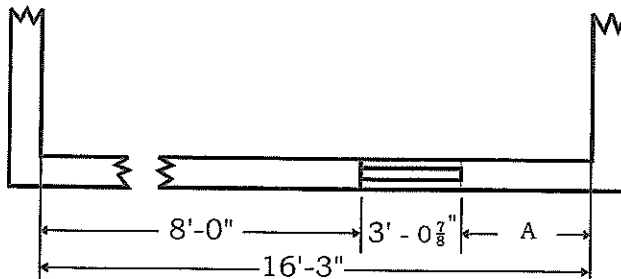

12) There are 13 risers in a staircase. What is the total rise (height) of the staircase if each riser is $7\frac{3}{8}$ "?

13) How many sheets of $\frac{5}{8}$ " plywood are there in a stack

- a) 15" high b) $8\frac{1}{8}$ " high

14) Calculate the missing dimension (B) in the drawing below:

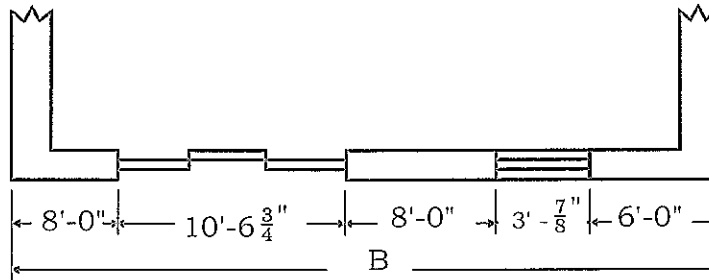

15) An apprentice cuts a piece of stock into 4 pieces. The lengths are $3\frac{3}{8}$ ", $2\frac{7}{16}$ ", $4\frac{1}{2}$ " and $1\frac{1}{4}$ ". If $\frac{1}{8}$ " is used up for each kerf (saw cut), what was the original length of the board?

Hint:

There were 3 kerfs made in cutting the board.

16) A steel post $103\frac{8}{16}$ " high is bolted to the top of a concrete pier that is $10\frac{1}{4}$ " high. The pier sits on top of a footing $12\frac{3}{4}$ " thick. What is the total distance from the bottom of the footing to the top of the post?

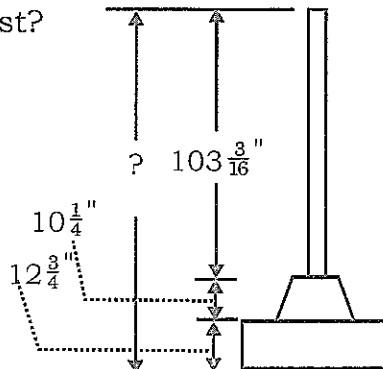

- 17) How thick would a stack of 7 sheets of $\frac{3}{8}$ " plywood be?
- 18) An apprentice divides a 4'-10" storey pole into eight equal spaces. What is the length of each space? Hint: Convert feet to inches.
- 19) On a scaled drawing where $\frac{1}{8}$ " is equal to 1' 0", how many feet would $7\frac{3}{8}$ " represent?
- 20) A floor is covered with flooring strips $2\frac{1}{3}$ " wide. How many strips are needed to cover a floor 117" wide?
- 21) Three boards, $5\frac{3}{8}$ ", $2\frac{1}{16}$ " and $3\frac{5}{8}$ " wide are glued together. What is the width of the resulting board?
- 22) The blueprint framing specifications state that the maximum size diameter hole that can be drilled into the centre of a joist at mid span is $\frac{1}{4}$ of the joist depth. What would the maximum size hole be for joist that is $9\frac{1}{4}$ " deep?
- 23) The concrete specifications state that the maximum size of aggregate for a wall form is $\frac{1}{5}$ of the narrowest dimension between the sides of the forms. What would the maximum size aggregate be for an 8" thick concrete wall?

ANSWER KEY

FRACTIONS

Page 43, **Defining Fractions**

- 1) proper fraction 2) mixed number 3) improper fraction
 4) whole number 5) proper fraction 6) mixed number
 7) proper fraction 8) improper fraction 9) improper fraction
 10) whole number 11) proper fraction 12) proper fraction
 13) mixed number 14) improper fraction 15) improper fraction
 16) mixed number

Page 43, **Writing Fractions**

- 1) $\frac{1}{2}$ 2) $\frac{1}{3}$ 3) $\frac{3}{8}$ 4) $\frac{7}{8}$
 5) $\frac{1}{3}$ 6) $\frac{3}{4}$ 7) $\frac{3}{16}$ 8) $\frac{10}{16}$

Page 44, **Changing Improper Fractions to Mixed Numbers**

- 1) 2 2) $1\frac{2}{8} = 1\frac{1}{4}$ 3) 2 4) 3
 5) $1\frac{1}{3}$ 6) $2\frac{2}{4} = 2\frac{1}{2}$ 7) $1\frac{1}{2}$ 8) $2\frac{1}{2}$
 9) $1\frac{5}{8}$ 10) 7 11) $1\frac{3}{4}$ 12) 3
 13) $1\frac{1}{4}$ 14) $3\frac{1}{2}$ 15) $1\frac{1}{16}$ 16) $1\frac{5}{16}$

Page 45, **Changing Mixed Numbers to Improper Fractions**

- 1) $\frac{3}{2}$ 2) $\frac{4}{3}$ 3) $\frac{9}{4}$ 4) $\frac{25}{8}$
 5) $\frac{4}{1}$ 6) $\frac{15}{2}$ 7) $\frac{15}{4}$ 8) $\frac{99}{16}$
 9) $\frac{11}{1}$ 10) $\frac{155}{16}$ 11) $\frac{37}{8}$ 12) $\frac{27}{8}$
 13) $\frac{17}{8}$ 14) $\frac{28}{3}$ 15) $\frac{21}{1}$ 16) $\frac{55}{8}$

Page 46, **Common Denominators**

1) $\frac{3}{4} = \frac{6}{8}$

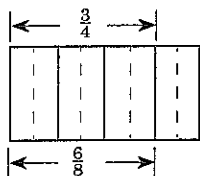

2) $\frac{1}{2} = \frac{4}{8}$

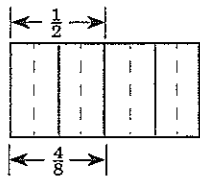

3) $\frac{1}{3} = \frac{2}{6}$

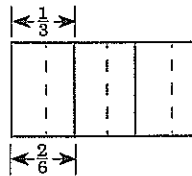

4) $\frac{1}{4} = \frac{2}{8}$

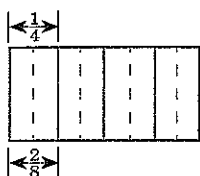

5) $\frac{3}{4} = \frac{12}{16}$

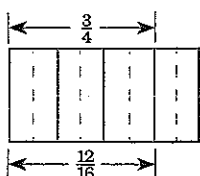
Page 47, **Common Denominators**

1) The LCD is 4, $\frac{1}{2} = \frac{2}{4}$

2) The LCD is 8, $\frac{1}{4} = \frac{2}{8}$

3) The LCD is 12, $\frac{1}{3} = \frac{4}{12}$

4) The LCD is 16, $\frac{3}{8} = \frac{6}{16}$

5) The LCD is 10, $\frac{1}{5} = \frac{2}{10}$, $\frac{1}{2} = \frac{5}{10}$

6) The LCD is 8, $\frac{3}{4} = \frac{6}{8}$

7) The LCD is 6, $\frac{1}{2} = \frac{3}{6}$, $\frac{1}{3} = \frac{2}{6}$

8) The LCD is 24, $\frac{1}{12} = \frac{2}{24}$, $\frac{1}{8} = \frac{3}{24}$

9) The LCD is 12, $\frac{2}{3} = \frac{8}{12}$, $\frac{3}{4} = \frac{9}{12}$

10) The LCD is 16, $\frac{5}{8} = \frac{10}{16}$

11) The LCD is 20, $\frac{3}{4} = \frac{15}{20}$, $\frac{2}{5} = \frac{8}{20}$

12) The LCD is 20, $\frac{3}{5} = \frac{15}{20}$

13) The LCD is 8, $\frac{1}{2} = \frac{4}{8}$

14) The LCD is 16, $\frac{3}{4} = \frac{12}{16}$

15) The LCD is 24, $\frac{2}{6} = \frac{8}{24}$, $\frac{3}{8} = \frac{9}{24}$

16) The LCD is 16, $\frac{3}{8} = \frac{6}{16}$

Page 48, **Multiplying Fractions**

1) $\frac{1}{12}$

2) $\frac{2}{15}$

3) $\frac{2}{12} = \frac{1}{6}$

4) $\frac{7}{40}$

5) $\frac{2}{4} = \frac{1}{2}$

6) $\frac{5}{3} = 1\frac{2}{3}$

7) $\frac{9}{2} = 4\frac{1}{2}$

8) $\frac{8}{3} = 2\frac{2}{3}$

9) $\frac{20}{3} = 6\frac{2}{3}$

10) $\frac{42}{5} = 8\frac{2}{5}$

11) $\frac{74}{4} = 18\frac{2}{4} = 18\frac{1}{2}$

12) $\frac{14}{4} = 3\frac{2}{4} = 3\frac{1}{2}$

13) $\frac{90}{24} = 3\frac{18}{24} = 3\frac{3}{4}$

14) $\frac{169}{32} = 5\frac{9}{32}$

$$15) \frac{45}{32} = 1\frac{13}{32} \qquad 16) \frac{65}{6} = 10\frac{5}{6} \qquad 17) \frac{100}{12} = 8\frac{4}{12} = 8\frac{1}{3}$$

$$18) \frac{21}{4} = 5\frac{1}{4} \qquad 19) \frac{969}{32} = 30\frac{9}{32} \qquad 20) \frac{255}{32} = 7\frac{31}{32}$$

Page 49, **Inverting Fractions**

- | | | | |
|--------------------|----------------------|--------------------|--------------------|
| 1) $\frac{8}{7}$ | 2) $\frac{4}{3}$ | 3) $\frac{1}{2}$ | 4) $\frac{3}{2}$ |
| 5) $\frac{2}{9}$ | 6) $\frac{4}{7}$ | 7) $\frac{8}{3}$ | 8) $\frac{8}{5}$ |
| 9) $\frac{2}{3}$ | 10) $\frac{16}{35}$ | 11) $\frac{8}{53}$ | 12) $\frac{4}{15}$ |
| 13) $\frac{4}{21}$ | 14) $\frac{16}{137}$ | 15) $\frac{4}{19}$ | 16) $\frac{2}{15}$ |

Page 51, **Dividing Fractions**

- | | | | |
|--|---|---|--|
| 1) $\frac{1}{3} \times \frac{2}{1} = \frac{2}{3}$ | 2) $\frac{2}{5} \times \frac{2}{1} = \frac{4}{5}$ | 3) $\frac{1}{4} \times \frac{3}{1} = \frac{3}{4}$ | 4) $\frac{2}{3} \times \frac{4}{3} = \frac{8}{9}$ |
| 5) $\frac{3}{7} \times \frac{9}{4} = \frac{27}{28}$ | 6) $\frac{2}{11} \times \frac{8}{5} = \frac{16}{55}$ | 7) $\frac{1}{3} \times \frac{3}{2} = \frac{3}{6} = \frac{1}{2}$ | 8) $\frac{5}{16} \times \frac{3}{2} = \frac{15}{32}$ |
| 9) $\frac{15}{2} \div \frac{1}{3} = \frac{15}{2} \times \frac{3}{1} = \frac{45}{2} = 22\frac{1}{2}$ | 10) $\frac{6}{1} \times \frac{3}{2} = \frac{18}{2} = 9$ | | |
| 11) $\frac{3}{1} \times \frac{4}{7} = \frac{12}{7} = 1\frac{5}{7}$ | 12) $\frac{2}{3} \times \frac{1}{4} = \frac{2}{12} = \frac{1}{6}$ | | |
| 13) $\frac{1}{16} \div \frac{9}{8} = \frac{1}{16} \times \frac{8}{9} = \frac{8}{144} = \frac{1}{18}$ | 14) $\frac{8}{3} \div \frac{4}{1} = \frac{8}{3} \times \frac{1}{4} = \frac{8}{12} = \frac{2}{3}$ | | |
| 15) $\frac{6}{5} \div \frac{3}{1} = \frac{6}{5} \times \frac{1}{3} = \frac{6}{15} = \frac{2}{5}$ | 16) $\frac{19}{8} \div \frac{1}{1} = \frac{19}{8} \times \frac{1}{1} = 2\frac{3}{8}$ | | |
| 17) $\frac{15}{2} \div \frac{7}{2} = \frac{15}{2} \times \frac{2}{7} = \frac{30}{14} = 2\frac{2}{14} = 2\frac{1}{7}$ | 18) $\frac{5}{4} \div \frac{19}{8} = \frac{5}{4} \times \frac{8}{19} = \frac{40}{76} = \frac{10}{19}$ | | |
| 19) $\frac{9}{8} \div \frac{8}{3} = \frac{9}{8} \times \frac{3}{8} = \frac{27}{64}$ | 20) $\frac{21}{8} \div \frac{19}{8} = \frac{21}{8} \times \frac{8}{19} = \frac{168}{152} = 1\frac{16}{152} = 1\frac{2}{19}$ | | |

Page 53, **Adding Fractions**

- | | | | |
|--|--|--------------------------------|---|
| 1) $\frac{3}{4}$ | 2) $\frac{4}{4} = 1$ | 3) $\frac{4}{8} = \frac{1}{2}$ | 4) $\frac{12}{8} = 1\frac{4}{8} = 1\frac{1}{2}$ |
| 5) $\frac{2}{4} + \frac{1}{4} = \frac{3}{4}$ | 6) $\frac{3}{6} + \frac{2}{6} = \frac{5}{6}$ | 7) $\frac{5}{6}$ | 8) $\frac{2}{8} + \frac{3}{8} = \frac{5}{8}$ |
| 9) $\frac{10}{16} + \frac{13}{16} = \frac{23}{16} = 1\frac{7}{16}$ | 10) $\frac{10}{12} + \frac{3}{12} = \frac{13}{12} = 1\frac{1}{12}$ | | |
| 11) $\frac{2}{8} + \frac{7}{8} = \frac{9}{8} = 1\frac{1}{8}$ | 12) $\frac{5}{16} + \frac{12}{16} = \frac{17}{16} = 1\frac{1}{16}$ | | |
| 13) $13\frac{2}{8} = 13\frac{1}{4}$ | 14) $6\frac{2}{16} + 4\frac{3}{16} = 10\frac{5}{16}$ | | |

15) $2\frac{2}{4} + 1\frac{1}{4} = 3\frac{3}{4}$

16) $5\frac{2}{6} + 7\frac{1}{6} = 12\frac{3}{6} = 12\frac{1}{2}$

17) $15\frac{6}{8} = 15\frac{3}{4}$

18) $2\frac{1}{16} + 3\frac{2}{16} + 7\frac{7}{16} = 12\frac{10}{16} = 12\frac{5}{8}$

19) $2\frac{4}{16} + 4\frac{8}{16} + 5\frac{7}{16} = 11\frac{19}{16} = 12\frac{3}{16}$

20) $3\frac{2}{8} + 9\frac{3}{8} + 1\frac{6}{8} = 13\frac{11}{8} = 14\frac{3}{8}$

Page 56, **Subtracting Fractions**

1) $\frac{2}{4} = \frac{1}{2}$

2) $\frac{2}{8} = \frac{1}{4}$

3) $\frac{8}{16} = \frac{1}{2}$

4) $\frac{4}{8} = \frac{1}{2}$

5) $\frac{3}{4} - \frac{2}{4} = \frac{1}{4}$

6) $\frac{3}{6} - \frac{2}{6} = \frac{1}{6}$

7) $\frac{3}{8} - \frac{2}{8} = \frac{1}{8}$

8) $\frac{11}{16} - \frac{6}{16} = \frac{5}{16}$

9) $2\frac{5}{8}$

10) $5\frac{10}{16} - 1\frac{5}{16} = 4\frac{5}{16}$

11) $3\frac{4}{6} - 1\frac{3}{6} = 2\frac{1}{6}$

12) $4\frac{3}{8} - 1\frac{2}{8} = 3\frac{1}{8}$

13) $2\frac{5}{4} - 1\frac{3}{4} = 1\frac{2}{4} = 1\frac{1}{2}$

14) $11\frac{11}{8} - 5\frac{5}{8} = 6\frac{6}{8} = 6\frac{3}{4}$

15) $2\frac{1}{4} - 1\frac{2}{4} = 1\frac{5}{4} - 1\frac{2}{4} = \frac{3}{4}$

16) $2\frac{2}{4} - \frac{3}{4} = 1\frac{6}{4} - \frac{3}{4} = 1\frac{3}{4}$

17) $4\frac{4}{4} - 1\frac{3}{4} = 3\frac{1}{4}$

18) $\frac{8}{8} - \frac{5}{8} = \frac{3}{8}$

19) $6\frac{16}{16} - \frac{15}{16} = 6\frac{1}{16}$

20) $5\frac{8}{8} - 4\frac{1}{8} = 1\frac{7}{8}$

21) $7\frac{5}{8} - 2\frac{6}{8} = 6\frac{13}{8} - 2\frac{6}{8} = 4\frac{7}{8}$

22) $15\frac{4}{16} - 13\frac{5}{16} = 14\frac{20}{16} - 13\frac{5}{16} = 1\frac{15}{16}$

23) $2\frac{2}{10} - 1\frac{1}{10} = 1\frac{1}{10}$

24) $3\frac{5}{8} - 1\frac{6}{8} = 2\frac{13}{8} - 1\frac{6}{8} = 1\frac{7}{8}$

Page 57, **Practice**

1) $\frac{1}{2} \times \frac{1}{4} = \frac{1}{8}$

2) $\frac{1}{4} \times \frac{1}{3} = \frac{1}{12}$

3) $3\frac{1}{4} + 6\frac{1}{8} + 2\frac{5}{16} = 3\frac{4}{16} + 6\frac{2}{16} + 2\frac{5}{16} = 11\frac{11}{16}$ "

4) $4\frac{1}{4} \times 8 = \frac{17}{4} \times \frac{8}{1} = \frac{136}{4} = 34$ '

5) $7\frac{1}{2} \div 1\frac{1}{2} = \frac{15}{2} \div \frac{3}{2} = \frac{15}{2} \times \frac{2}{3} = \frac{30}{6} = 5$ pieces

6) $\frac{5}{8} + 9\frac{1}{4} + 11\frac{3}{8} = \frac{5}{8} + 9\frac{2}{8} + 11\frac{3}{8} = 20\frac{10}{8} = 21\frac{2}{8} = 21\frac{1}{4}$ "

7) $A = 7\frac{3}{4} + 2\frac{3}{8} = 7\frac{6}{8} + 2\frac{3}{8} = 9\frac{9}{8} = 10\frac{1}{8}$ "

8) $B = 7\frac{1}{2} + 1\frac{7}{8} = 7\frac{4}{8} + 1\frac{7}{8} = 8\frac{11}{8} = 9\frac{3}{8}$ "

ANSWER KEYS

- 9) $C = 5\frac{1}{2} + 1\frac{1}{2} = 6\frac{2}{2} = 7''$
- 10) $D = A + 6\frac{1}{4} = 10\frac{1}{8} + 6\frac{1}{4} = 10\frac{1}{8} + 6\frac{2}{8} = 16\frac{3}{8}''$
- 11) $A = 16' 3'' - (8' + 3' \frac{7}{8}'')$
 $= 16' 3'' - 11' \frac{7}{8}'' = 5' 2\frac{1}{8}''$
- 12) $13 \times 7\frac{3}{8} = \frac{13}{1} \times \frac{59}{8} = \frac{767}{8} = 95\frac{7}{8}'' = 7' - 11\frac{7}{8}''$
- 13a) $15 \div \frac{5}{8} = \frac{15}{1} \div \frac{5}{8} = \frac{15}{1} \times \frac{8}{5} = \frac{120}{5} = 24$ sheets
- b) $8\frac{1}{8} \div \frac{5}{8} = \frac{65}{8} \div \frac{5}{8} = \frac{65}{8} \times \frac{8}{5} = \frac{520}{40} = 13$ sheets
- 14) $B = 8' + 10' 6\frac{3}{4}'' + 8' + 3' \frac{7}{8}'' + 6'$
 $= 35' 6\frac{13}{8}'' = 35' 7\frac{5}{8}''$
- 15) $\text{kerf} = \frac{1}{8} \times \frac{3}{1} = \frac{3}{8}''$
length of board =
 $3\frac{3}{8} + 2\frac{7}{16} + 4\frac{1}{2} + 1\frac{1}{4} + \frac{3}{8} = 3\frac{6}{16} + 2\frac{7}{16} + 4\frac{8}{16} + 1\frac{4}{16} + \frac{6}{16} = 10\frac{31}{16} = 11\frac{15}{16}''$
- 16) $103\frac{3}{16} + 10\frac{1}{4} + 12\frac{3}{4} = 103\frac{3}{16} + 10\frac{4}{16} + 12\frac{12}{16} = 125\frac{19}{16} = 126\frac{3}{16}''$
- 17) $7 \times \frac{3}{8} = \frac{21}{8} = 2\frac{5}{8}''$
- 18) $4' \times 12 = 48''$
 $(48 + 10) \div 8 = 58 \div 8 = 7\frac{2}{8} = 7\frac{1}{4}''$
- 19) $7\frac{3}{8} \div \frac{1}{8} = \frac{59}{8} \times \frac{8}{1} = \frac{472}{8} = 59'$
- 20) $117 \div 2\frac{1}{3} = \frac{117}{1} \div \frac{7}{3} = \frac{117}{1} \times \frac{3}{7} = \frac{351}{7} = 50\frac{1}{7} = 51$ strips
- 21) $5\frac{3}{8} + 2\frac{1}{16} + 3\frac{5}{8} = 5\frac{6}{16} + 2\frac{1}{16} + 3\frac{10}{16} = 10\frac{17}{16} = 11\frac{1}{16}''$
- 22) $9\frac{1}{4} \times \frac{1}{4} = \frac{37}{4} \times \frac{1}{4} = \frac{37}{16} = 2\frac{5}{16}''$
- 23) $\frac{8}{1} \times \frac{1}{5} = \frac{8}{5} = 1\frac{3}{5}''$