

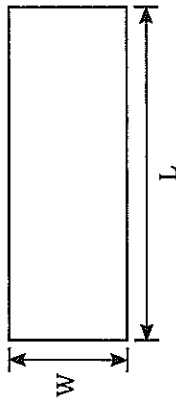
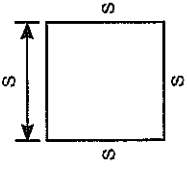
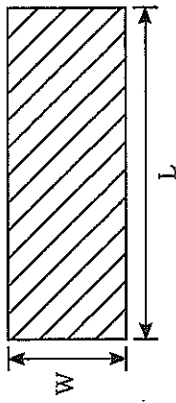
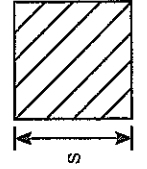
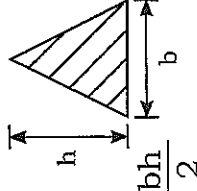
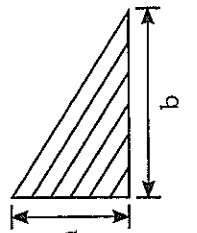
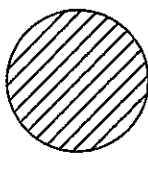
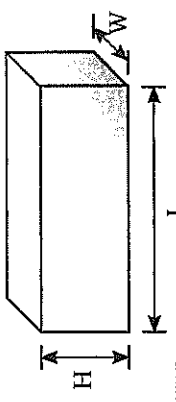
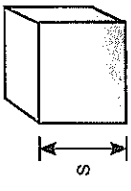
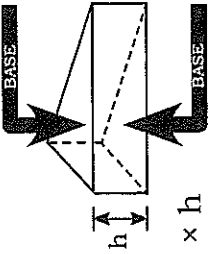
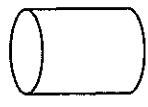

FORMULAS FOR PERIMETER, AREA AND VOLUME

Perimeter	Area	Volume
<p>1 - Dimensional</p>  <p><math>P = 2(L + W)</math></p>  <p><math>P = 4s</math></p>	<p>2 - Dimensional</p>  <p><math>A = LW</math></p>  <p><math>A = s^2</math></p>  <p><math>A = \frac{bh}{2}</math></p>  <p><math>A = \frac{bh}{2}</math></p>  <p><math>A = \pi r^2</math></p>	<p>3 - Dimensional</p>  <p><math>V = LWH</math></p>  <p><math>V = s^3</math></p>  <p><math>V = \text{area of base} \times h</math></p>  <p><math>V = \pi r^2 h</math></p>  <p><math>V = \frac{\pi r^2 h}{3}</math></p>  <p><math>V = \frac{\pi d^3}{6}</math> or <math>V = \frac{4\pi r^3}{3}</math></p>

Perimeter	Area	Volume
<b>1 - Dimensional</b>  $P = 2(b + s)$	<b>2 - Dimensional</b>  $A = bh$	<b>3 - Dimensional</b>  $V = \text{area of base} \times h$
 $P = s_1 + s_2 + s_3 + s_4$	 $A = \frac{(b_1 + b_2)}{2} \times h$	 $V = \text{area of base} \times h$
$P = 6s$ 	$A = 2.59 \times s^2$ 	$V = \text{area of base} \times h$ 

Note: Lateral Area (L.A.) is the area of all the surfaces except for the bases. Surface Area (S.A.) is the L.A. plus the area of the bases.

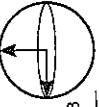
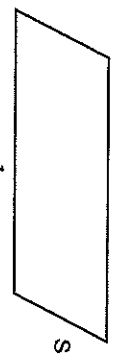
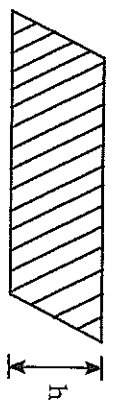
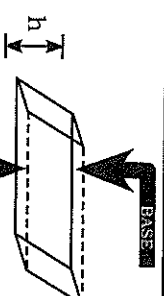
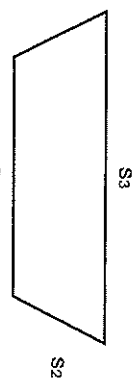
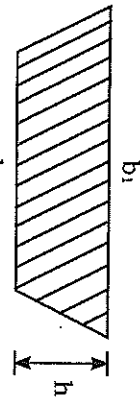
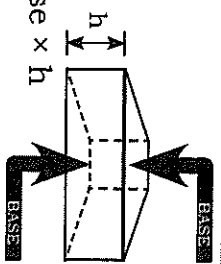
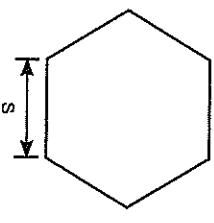
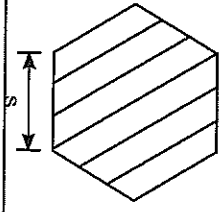
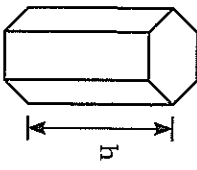
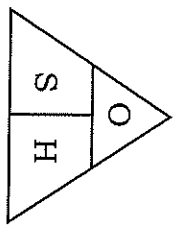
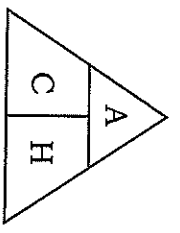
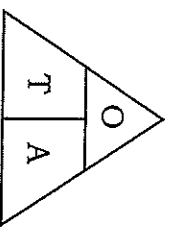
<b>Pythagorean Theorem (3-4-5 Method)</b> $a^2 + b^2 = c^2$ $a^2 = c^2 - b^2$ $b^2 = c^2 - a^2$	<b>Trigonometry</b> <div style="display: flex; justify-content: space-around; align-items: center;"> <div style="text-align: center;"> <math>\text{SOH}</math>   </div> <div style="text-align: center;"> <math>\text{CAH}</math>   </div> <div style="text-align: center;"> <math>\text{TOA}</math>   </div> </div>
--	--