

VOLUME

INTRODUCTION

Volume is three-dimensional. It is the amount of space inside an object or the amount of space an object occupies. Volume is always measured in cubic units. In this chapter, you will learn how to calculate the volume of different solids.

It is important you understand the difference between perimeter, area and volume, and how each is measured. The table below compares perimeter, area and volume.

| | | |
|-----------------|-------------------------------------|---------------------------------------|
| $12" = 1'$ | $144 \text{ in}^2 = 1 \text{ ft}^2$ | $1,728 \text{ in}^3 = 1 \text{ ft}^3$ |
| ↓ | ↓ | ↓ |
| perimeter | area | volume |
| One-dimensional | Two-dimensional | Three-dimensional |
| inches | in^2 | in^3 |
| feet | ft^2 | ft^3 |
| yards | yd^2 | yd^3 |
| mm | mm^2 | mm^3 |
| cm | cm^2 | cm^3 |
| m | m^2 | m^3 |

At the end of this chapter you will be able to:

- Calculate the volume of simple and complex shapes.
- Solve word problems using volume.
- Solve applications using volume.

Note: If your calculator doesn't have π , use 3.1416. Your answer will be slightly different because it is slightly less accurate.

$$V = \pi r^2 h = \pi \times 2^2 \times 6 = 75.4 \text{ ft}^3$$

(rounded to the nearest tenth)

The volume of the cylinder is 75.4 ft³.

Example 3:

Step 1: Draw a diagram and label it.

Step 2: Write the formula.

$$V = \frac{\pi r^2 h}{3}$$

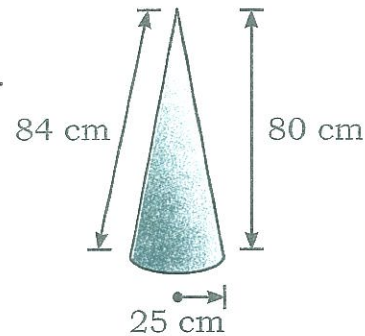

Note: The formula requires the height of the cone. Height is the perpendicular measurement from the base to the top of the cone. Make sure you use the height and not the slant height.

Step 3: Calculate the volume.

$$V = \frac{\pi r^2 h}{3} = \frac{\pi \times 25^2 \times 80}{3} = \frac{157\,079.6}{3} = 52\,359.9 \text{ cm}^3$$

The volume of the cone is 52 359.9 cm³.

VOLUME

Calculate the volume of the following solids. Round off answers to two decimal places. If your calculator doesn't have π , use 3.1416.

1) $V =$

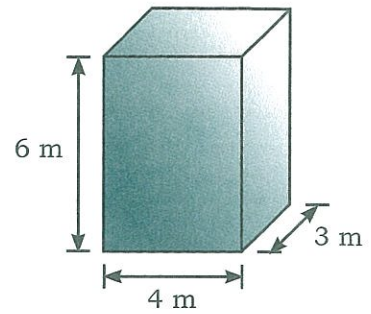

2) $V =$

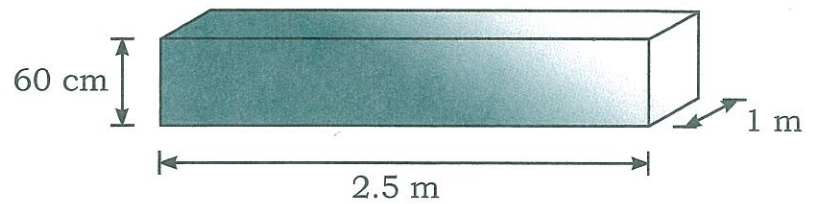

3) $V =$

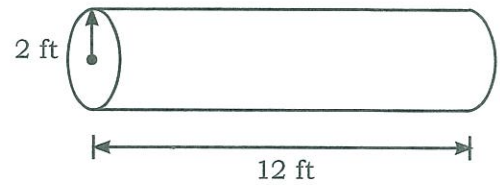

4) $V =$

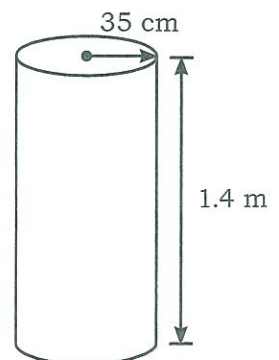

5) $V =$

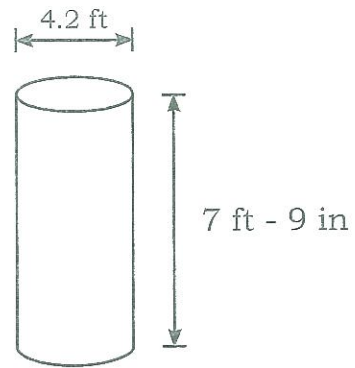

6) $V =$

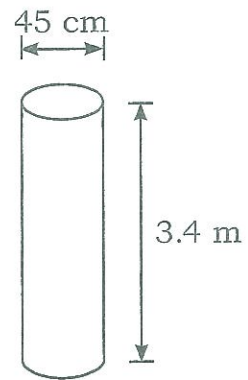

7) $V =$

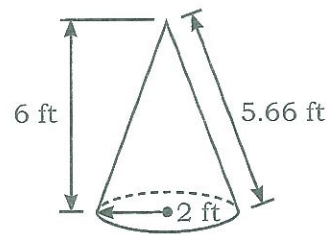

8) $V =$

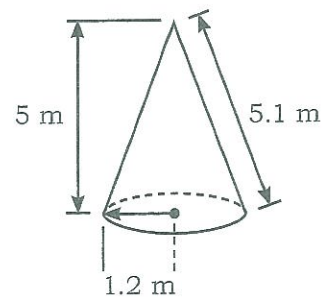

VOLUME

9) $V =$

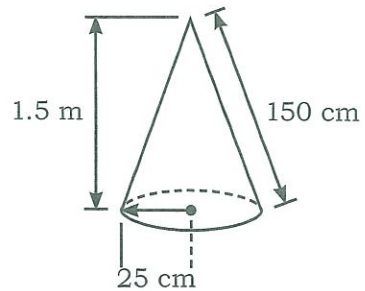

10) $V =$

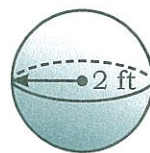

11) $V =$

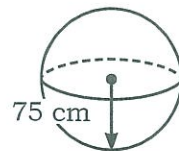

12) $V =$

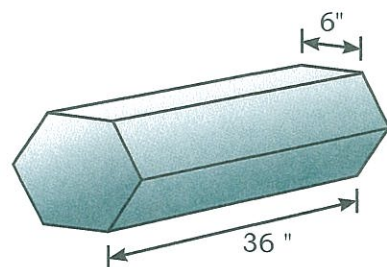

13) $V =$

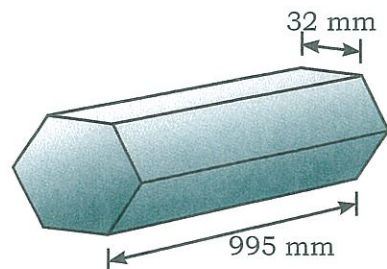

14) $V =$

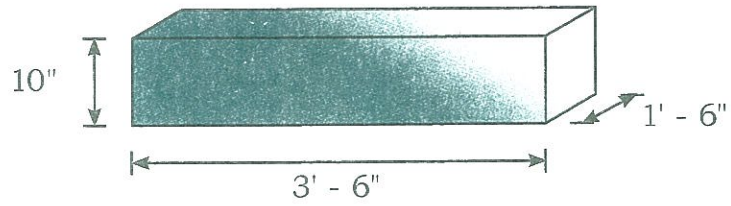

15) $V =$

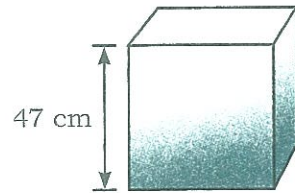

16) $V =$

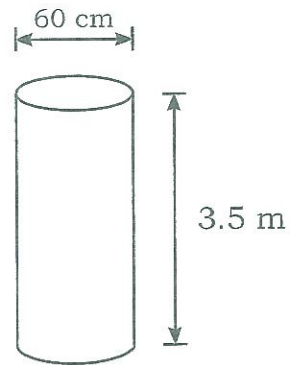

17) $V =$

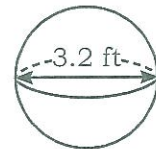

18) $V =$

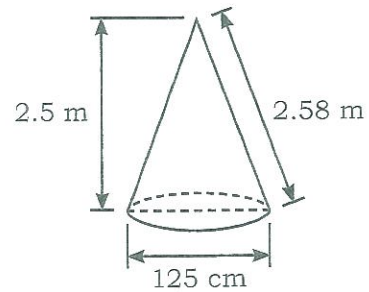

VOLUME

19) $V =$

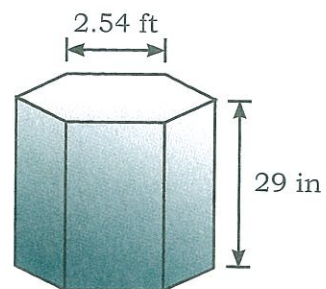

20) $V =$

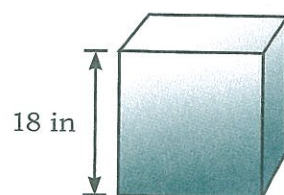

CALCULATING THE VOLUME OF COMPLEX SHAPES

Sometimes you need to do more than one calculation or use more than one formula to calculate volume because the solid is a combination of shapes. You will need to divide the solid into shapes you are familiar with and calculate the volume of each of those shapes. To get the total volume, you will need to add or subtract the volume of each of the shapes. You may need to use the same formula several times or you may need to use more than one formula. The steps for calculating the volume of a complex shape are the same.

Example 1:

A concrete wall and footing are poured at the same time. Calculate the volume of concrete that is needed. Look at the diagram below.

Step 1: Draw a diagram and label it.

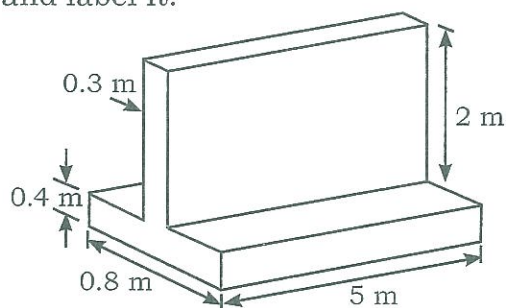

Step 2: Write the formula(s).
Think of the shape as being two rectangular solids called A and B.

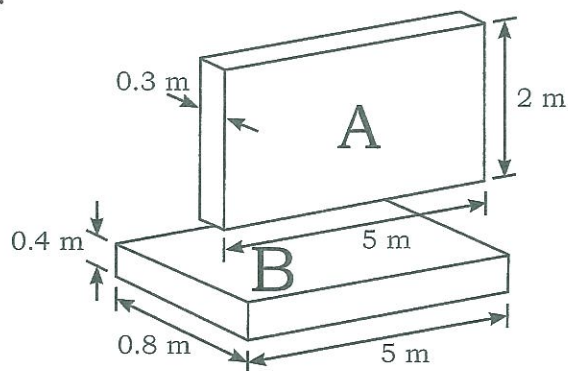

$$V = LWH$$

Step 3: Calculate the volume.
 Volume of wall = $LWH = 5 \text{ m} \times .3 \text{ m} \times 2 = 3 \text{ m}^3$
 Volume of footing = $LWH = 5 \text{ m} \times .8 \text{ m} \times .4 \text{ m} = 1.6 \text{ m}^3$
 Total Volume = $1.6 \text{ m}^3 + 3 \text{ m}^3 = 4.6 \text{ m}^3$
 The volume of the concrete wall and footing is 4.6 m^3 .

Remember:

There is often more than one way to solve a math problem.

Example 2:

Calculate the volume of the concrete figure below.

Step 1: Draw a diagram and label it.

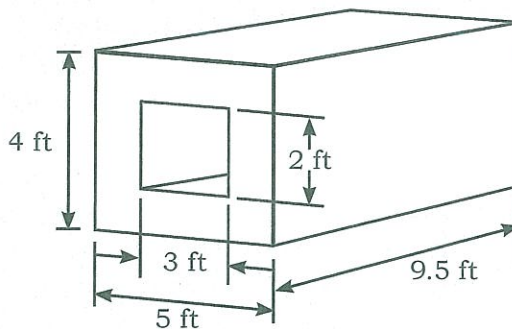

Step 2: Write the formula(s).
 $V = LWH$

Step 3: Calculate the volume.
 Big volume = $LWH = 9.5 \text{ ft} \times 5 \text{ ft} \times 4 \text{ ft} = 190 \text{ ft}^3$
 Small volume = $LWH = 9.5 \text{ ft} \times 3 \text{ ft} \times 2 \text{ ft} = 57 \text{ ft}^3$
 Total Volume = $190 \text{ ft}^3 - 57 \text{ ft}^3 = 133 \text{ ft}^3$
 The volume of the concrete figure is 133 ft^3 .

Calculate the volume of the following solids. Round off answers to two decimal places. If your calculator doesn't have π , use 3.1416.

1) $V =$

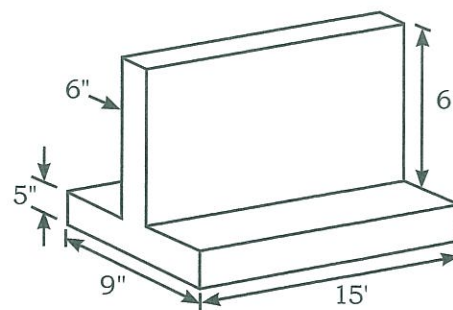

2) $V =$

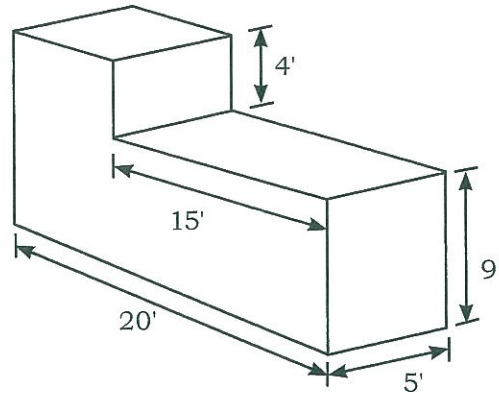

3) $V =$

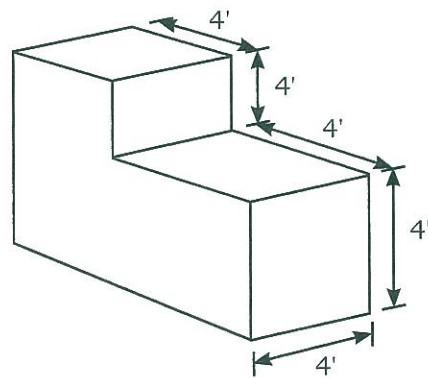

4) $V =$

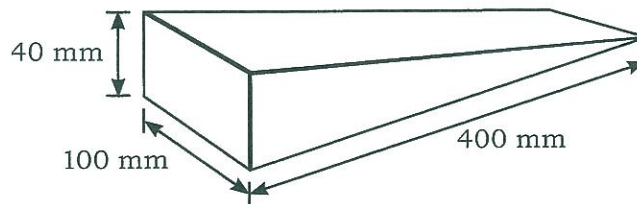

5) $V =$

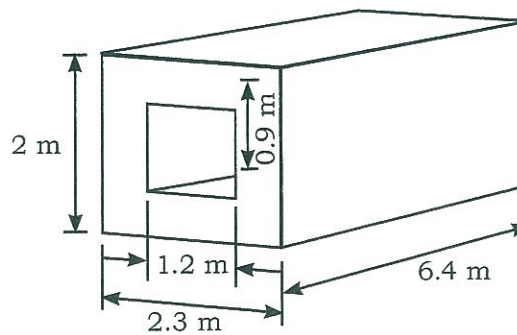

Hint:

A wedge is a rectangular solid cut diagonally in half.

VOLUME

6) $V =$

Hint:

Read the diagram carefully. Decide what shapes are used.

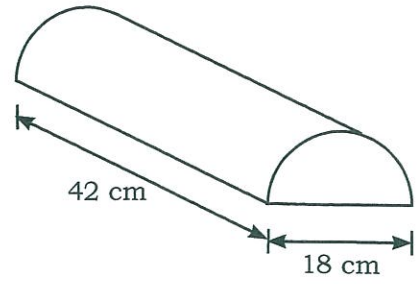

7) $V =$

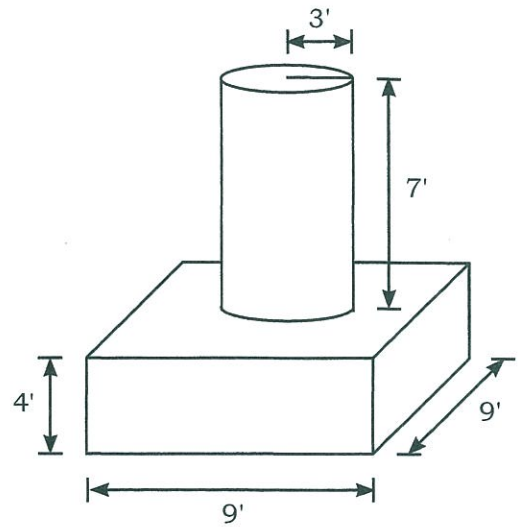

8) $V =$

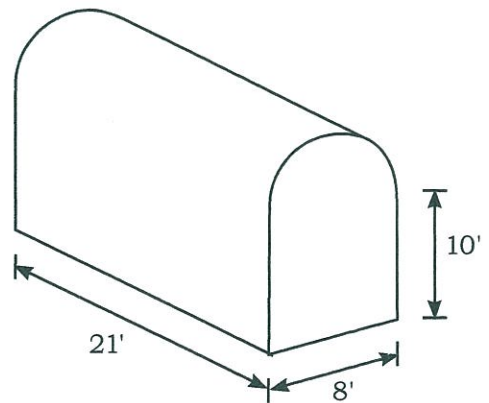

9) $V =$

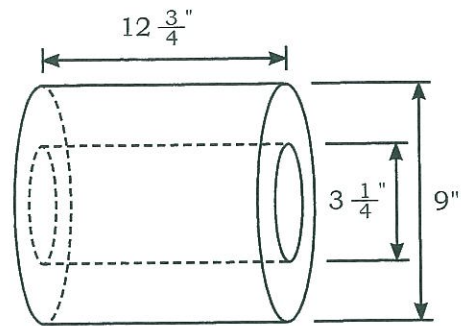

10) $V =$

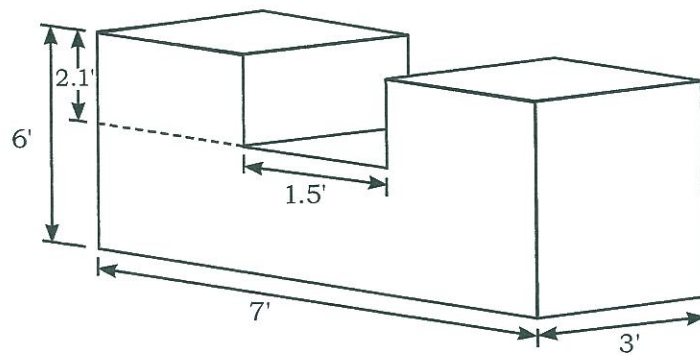

11) $V =$

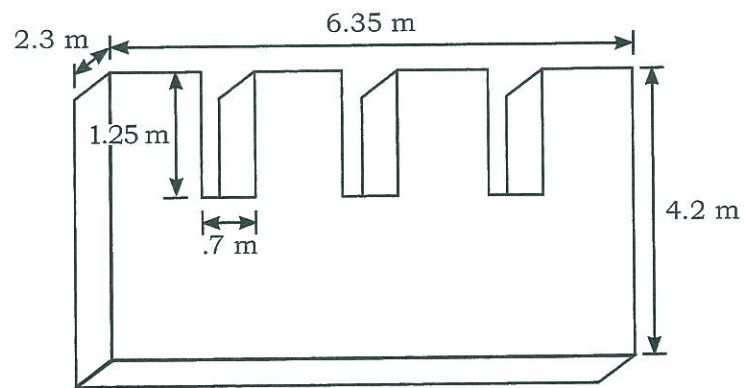

12) $V =$

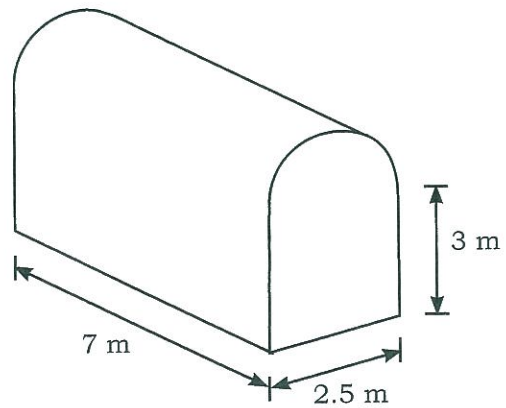

VOLUME

13) $V =$

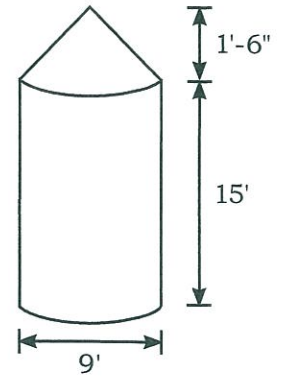

14) $V =$

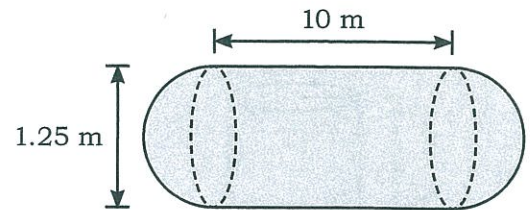

15) $V =$

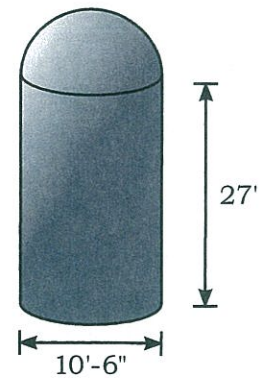

CALCULATING THE HEIGHT OR DIAMETER WHEN YOU KNOW THE VOLUME

Sometimes you know the volume of a shape and need to work backwards to calculate one of the sides or the diameter. You work with the same formula(s).

- Step 1: Draw a diagram and label it with the known information.
- Step 2: Write the formula(s) required.
- Step 3: Calculate the side.

Example 1:

Calculate the length of the rectangular solid in the diagram below.

- Step 1: Draw a diagram and label it with the known information.

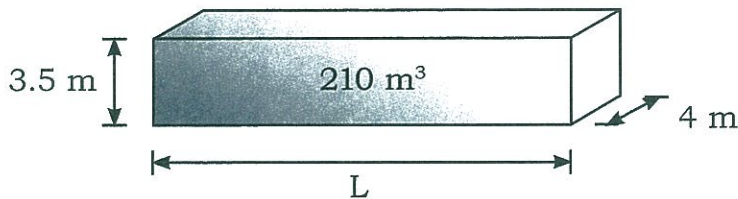

- Step 2: Write the formula(s) required.
 $V = LWH$
- Step 3: Calculate the side.

$$V = LWH$$

$$210 \text{ m}^3 = L \times 4 \times 3.5$$

$$210 \text{ m}^3 = L \times 14$$

$$\frac{210}{14} = L$$

$$\frac{210}{14} = 15$$

The length of the side is 15 m.

Example 2:

Calculate the radius of the cylinder in the diagram below.

Step 1: Draw a diagram and label it with the known information.

Step 2: Write the formula(s) required.
 $V = \pi r^2 h$

Step 3: Calculate the radius.

$$V = \pi r^2 h$$

$$25 \text{ ft}^2 = \pi r^2 \times 4.2 \text{ ft}$$

$$\frac{25}{4.2} = \pi r^2$$

$$5.95 = \pi r^2$$

$$\frac{5.95}{\pi} = r^2$$

$$1.89 = r^2$$

$$\sqrt{1.89} = r$$

$$1.38 = r$$

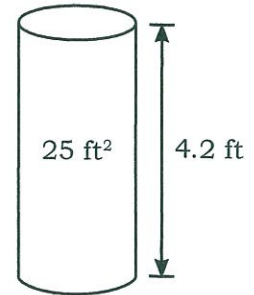

The radius of the cylinder is 1.38 ft.

Calculate the missing side in the shapes below. Round off to two decimal places. If your calculator doesn't have π , use 3.1416.

- 1) Calculate the height of the rectangular solid.

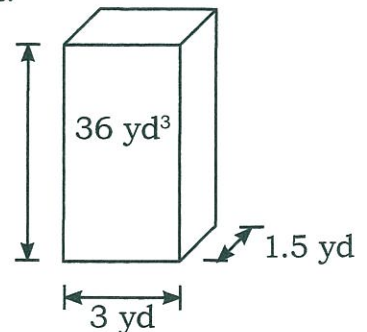

- 2) Calculate the width of the rectangular solid.

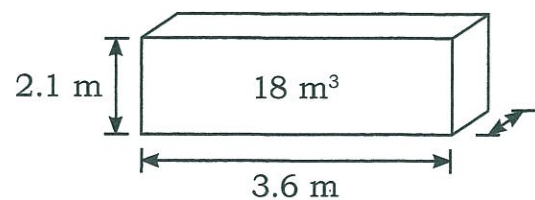

- 3) Calculate the radius of the cylinder.

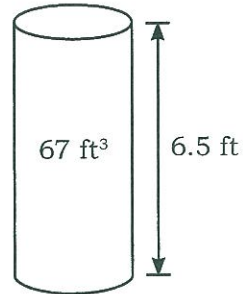

- 4) Calculate the height of the cylinder.

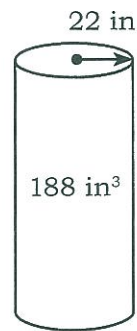

- 5) Calculate the diameter of the cylinder.

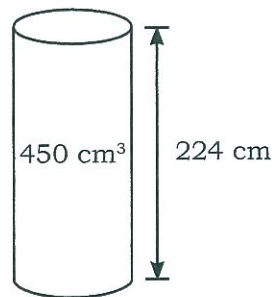

- 6) Calculate the height of the cone.



- 7) Calculate the diameter of the cone.

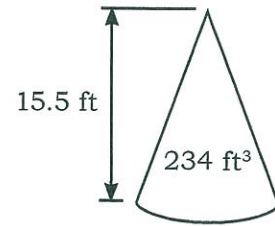

PRACTICE

Round up answers to the nearest whole yd^3 or m^3 .

- 1) How many cubic yards of concrete are needed for a driveway section that measures 6 yards long, 3 yards wide, and 1 foot thick?

- 2) Calculate the volume of concrete needed in cubic metres to fill a form that measures 3 m high by 400 mm wide by 12 m long.

- 3) A carpenter needs to pour a rectangular slab that is 13 m long, 6 m wide, and 0.3 m thick. Calculate the volume.

- 4) Calculate the volume of fill in cubic yards required to fill a hole 5.5 ft long, 2 ft wide and 3.6 ft deep. Add 30% to allow for compaction.

Hint:

$$1 \text{ yd}^3 = 27 \text{ ft}^3$$

- 5) A pile of gravel is in the shape of a cone. The diameter of the pile is 6.5 m and the height is 2.3 m. How many cubic metres of gravel are in the pile?
- 6) How many cubic yards of concrete are needed to pour a concrete retaining wall that measures 39 feet long by 1.6 feet wide by 5 feet high?
- 7) Calculate the cubic meters of concrete needed to fill 8 cylindrical forms that are the same size. The radius measures 0.4 m and the height is 4.5 m.
- 8) Nine footings are required to support nine steel columns. How many cubic yards of concrete are needed to pour nine footings that are $24'' \times 24'' \times 24''$?

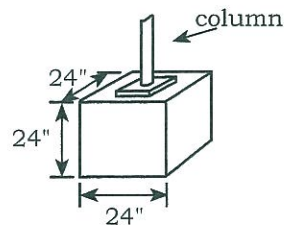

- 9) Calculate the cubic yards of concrete needed to fill the stair form shown below.

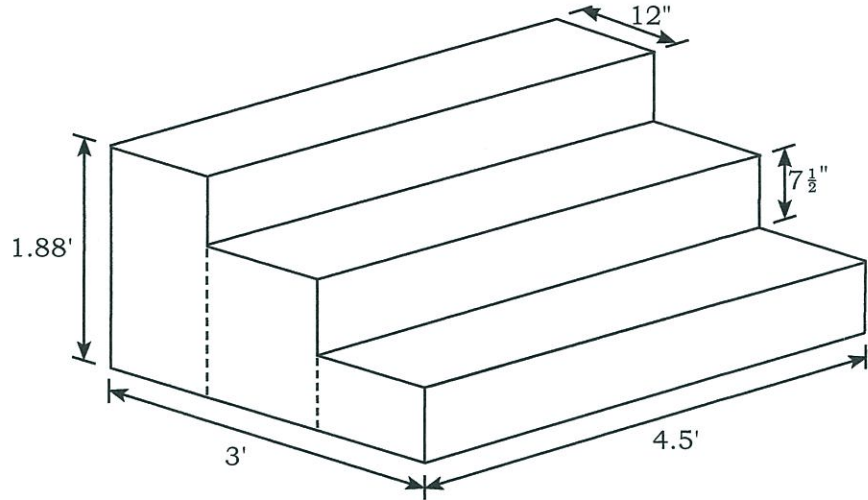

- 10) Fill is needed for an excavation that measures 9 feet long by 15 feet wide by 6.4 feet deep. Calculate the amount of available fill piled in a cone shape that has a 12 foot diameter and is 7 feet high. Calculate the cubic yards of additional fill the contractor needs to order. Allow for 25% compaction.

- 11) The fill excavated for a swimming pool must be hauled away. A truck has a capacity for 27 yd^3 . How many truckloads have to be hauled away?

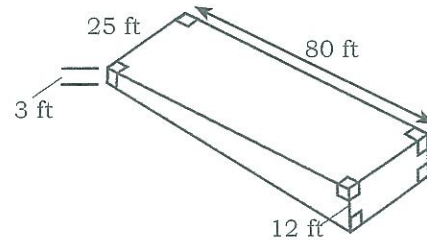

- 12) Calculate the cubic yards of earth that must be removed for the excavation shown below. The excavation is 8.5 ft. deep. A truck has a capacity for 27 yd^3 . How many truckloads of earth have to be hauled away?

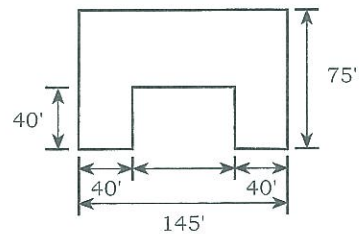

Hint:

$$27 \text{ ft}^3 = 1 \text{ yd}^3$$

ANSWER KEY

GEOMETRY - VOLUME

Page 180, **Calculating Volume**

1) $V = LWH = 4 \text{ m} \times 3 \text{ m} \times 6 \text{ m} = 72 \text{ m}^3$

2) $V = LWH = 2.5 \text{ m} \times 1 \text{ m} \times 0.6 \text{ m} = 1.5 \text{ m}^3$

3) $V = \pi r^2 h = \pi \times (2 \text{ ft})^2 \times 12 \text{ ft} = 150.8 \text{ ft}^3$

4) $35 \text{ cm} = 0.35 \text{ m}$
 $V = \pi r^2 h = \pi \times (0.35 \text{ m})^2 \times 1.4 \text{ m} = 0.54 \text{ m}^3$

5) $\text{radius} = \text{diameter} \div 2 = 4.2 \div 2 = 2.1 \text{ ft}$
 $7 \text{ ft} - 9 \text{ in} = 7.75 \text{ ft}$
 $V = \pi r^2 h = \pi \times (2.1 \text{ ft})^2 \times 7.75 \text{ ft} = 107.37 \text{ ft}^3$

6) $\text{radius} = \text{diameter} \div 2 = 0.45 \div 2 = 0.23 \text{ m}$
 $V = \pi r^2 h = \pi \times (0.23 \text{ m})^2 \times 3.4 \text{ m} = 0.57 \text{ m}^3$

7) $V = \frac{\pi r^2 h}{3} = \frac{\pi \times (2 \text{ ft})^2 \times 6 \text{ ft}}{3} = \frac{75.4 \text{ ft}^3}{3} = 25.13 \text{ ft}^3$

8) $V = \frac{\pi r^2 h}{3} = \frac{\pi \times (1.2 \text{ m})^2 \times 5 \text{ m}}{3} = \frac{22.62 \text{ m}^3}{3} = 7.54 \text{ m}^3$

9) $25 \text{ cm} = 0.25 \text{ m}$
 $V = \frac{\pi r^2 h}{3} = \frac{\pi \times (0.25 \text{ m})^2 \times 1.5 \text{ m}}{3} = \frac{0.29 \text{ m}^3}{3} = 0.1 \text{ m}^3$

10) $\text{diameter} = r \times 2 = 2 \times 2 = 4 \text{ ft}$
 $V = \frac{\pi d^3}{6} = \frac{\pi \times (4 \text{ ft})^3}{6} = \frac{201.06 \text{ ft}^3}{6} = 33.51 \text{ ft}^3$

11) $\text{diameter} = r \times 2 = 75 \times 2 = 150 \text{ cm}$
 $V = \frac{\pi d^3}{6} = \frac{\pi \times (150 \text{ cm})^3}{6} = \frac{10\,602\,875.21 \text{ cm}^3}{6} = 1\,767\,145.87 \text{ cm}^3$

12) $V = 2.59 \times s^2 \times h = 2.59 \times (6 \text{ in})^2 \times 36 \text{ in} = 3\,356.64 \text{ in}^3$

13) $V = 2.59 \times s^2 \times h = 2.59 \times (32 \text{ mm})^2 \times 995 \text{ mm} = 2\,638\,899.2 \text{ mm}^3$

14) $10'' = 83'$
 $V = LWH = 3.5 \text{ ft} \times 1.5 \text{ ft} \times 0.83 \text{ ft} = 4.36 \text{ ft}^3$

15) $V = s^3 = (47 \text{ cm})^3 = 103\,823 \text{ cm}^3$

16) radius = diameter \div 2 = 60 cm \div 2 = 30 cm
 30 cm = 0.30 m

$$V = \pi r^2 h = \pi \times (0.30 \text{ m})^2 \times 3.5 \text{ m} = 0.99 \text{ m}^3$$

17) $V = \frac{\pi d^3}{6} = \frac{\pi \times (3.2 \text{ ft})^3}{6} = \frac{102.94 \text{ ft}^3}{6} = 17.16 \text{ ft}^3$

18) 125 cm = 1.25 m

radius = diameter \div 2 = 1.25 \div 2 =

$$V = \frac{\pi r^2 h}{3} = \frac{\pi \times (0.625 \text{ m})^2 \times 2.5 \text{ m}}{3} = \frac{3.07 \text{ m}}{3} = 1.02 \text{ m}^3$$

19) 29 in = 2.42 ft

$$V = 2.59 \times s^2 \times h = 2.59 \times (2.54 \text{ ft})^2 \times 2.42 = 40.44 \text{ ft}^3$$

20) $V = s^3 = (18 \text{ in})^3 = 5\,832 \text{ in}^3$

Page 186, **Calculating the Volume of Complex Shapes**

1) 6 in = 0.5 ft

5 in = 0.42 ft

9 in = 0.75 ft

Volume of wall = LWH = 15 ft \times 0.5 ft \times 6 ft = 45 ft³

Volume of footing = LWH = 15 ft \times 0.75 ft \times 0.42 ft = 4.73 ft³

Total volume = 45 ft³ + 4.73 ft³ = 49.73 ft³

2) Volume of large rectangular solid = LWH = 20 ft \times 5 ft \times 9 ft = 900 ft³

Volume of small rectangular solid = LWH = 5 ft \times 5 ft \times 4 ft = 100 ft³

Total volume = 900 ft³ + 100 ft³ = 1 000 ft³

3) Volume of cube = $s^3 = (4 \text{ m})^3 = 64 \text{ m}^3$

Volume of rectangular solid = 4 m \times 4 m \times 8 m = 128 m³

Total volume = 64 m³ + 128 m³ = 192 m³

4) Volume = LWH = 400 mm \times 100 mm \times 40 mm = 1 600 000 mm³

Total volume = 1 600 000 mm³ \div 2 = 800 000 mm³

5) Volume of large rectangular solid =

LWH = 6.4 m \times 2.3 m \times 2 m = 29.44 m³

Volume of small rectangular solid =

LWH = 6.4 m \times 1.2 m \times 0.9 m = 6.91 m³

Total volume = 29.44 m³ - 6.91 m³ = 22.53 m³

- 6) radius = diameter \div 2 = 18 cm \div 2 = 9 cm
 $V = \pi r^2 h = \pi \times (9 \text{ cm})^2 \times 42 \text{ cm} = 10\,687.7 \text{ cm}^3$
 Total volume = $10\,687.7 \text{ cm}^3 \div 2 = 5\,343.85 \text{ cm}^3$
- 7) Volume of cylinder = $\pi r^2 h = \pi \times (3 \text{ ft})^2 \times 7 \text{ ft} = 197.92 \text{ ft}^3$
 Volume of rectangular solid = LWH = $9 \text{ ft} \times 9 \text{ ft} \times 4 \text{ ft} = 324 \text{ ft}^3$
 Total volume = $197.92 \text{ ft}^3 + 324 \text{ ft}^3 = 521.92 \text{ ft}^3$
- 8) Volume of rectangular solid = LWH = $21 \text{ ft} \times 8 \text{ ft} \times 10 \text{ ft} = 1\,680 \text{ ft}^3$
 radius = diameter \div 2 = $8 \div 2 = 4 \text{ ft}$
 Volume of cylinder = $\pi r^2 h = \pi \times (4 \text{ ft})^2 \times 21 \text{ ft} = 1\,055.58 \text{ ft}^3$
 Volume of half cylinder = $1\,055.58 \text{ ft}^3 \div 2 = 527.79 \text{ ft}^3$
 Total volume = $1\,680 \text{ ft}^3 + 527.79 \text{ ft}^3 = 2\,207.79 \text{ ft}^3$
- 9) radius = diameter \div 2 = $9 \div 2 = 4.5 \text{ in}$
 Volume of large cylinder = $\pi r^2 h = \pi \times (4.5 \text{ in})^2 \times 12.75 \text{ in} = 811.12 \text{ in}^3$
 radius = diameter \div 2 = $3.25 \div 2 = 1.63 \text{ in}$
 Volume of small cylinder = $\pi r^2 h = \pi \times (1.63 \text{ in})^2 \times 12.75 \text{ in} = 106.42 \text{ in}^3$
 Total volume = $811.12 \text{ in}^3 - 106.42 \text{ in}^3 = 704.7 \text{ in}^3$
- 10) Volume of large rectangular solid = LWH = $7 \text{ ft} \times 3 \text{ ft} \times 6 \text{ ft} = 126 \text{ ft}^3$
 Volume of small rectangular solid = LWH =
 $1.5 \text{ ft} \times 3 \text{ ft} \times 2.1 \text{ ft} = 9.45 \text{ ft}^3$
 Total volume = $126 \text{ ft}^3 - 9.45 \text{ ft}^3 = 116.55 \text{ ft}^3$
- 11) Volume of large rectangular solid = LWH =
 $6.35 \text{ m} \times 2.3 \text{ m} \times 4.2 \text{ m} = 61.34 \text{ m}^3$
 Volume of small rectangular solid = LWH =
 $0.7 \text{ m} \times 2.3 \text{ m} \times 1.25 \text{ m} = 2.01 \text{ m}^3$
 Total volume =
 $61.34 \text{ m}^3 - (2.01 \text{ m}^3 \times 3) = 61.34 \text{ m}^3 - 6.03 \text{ m}^3 = 55.31 \text{ m}^3$
- 12) Volume of rectangular solid = LWH = $7 \text{ m} \times 2.5 \text{ m} \times 3 \text{ m} = 52.5 \text{ m}^3$
 radius = diameter \div 2 = $2.5 \div 2 = 1.25 \text{ m}$
 Volume of cylinder = $\pi r^2 h = \pi \times (1.25 \text{ m})^2 \times 7 \text{ m} = 34.36 \text{ m}^3$
 Volume of half cylinder = $34.36 \text{ m}^3 \div 2 = 17.18 \text{ m}^3$
 Total volume = $52.5 \text{ m}^3 + 17.18 \text{ m}^3 = 69.68 \text{ m}^3$
- 13) radius = diameter \div 2 = $9 \div 2 = 4.5 \text{ ft}$
 Volume of cylinder = $\pi r^2 h = \pi \times (4.5 \text{ ft})^2 \times 15 \text{ ft} = 954.26 \text{ ft}^3$
 Volume of cone =
 $\frac{\pi r^2 h}{3} = \frac{\pi \times (4.5 \text{ ft})^2 \times 1.5 \text{ ft}}{3} = \frac{95.43 \text{ ft}^3}{3} = 31.81 \text{ ft}^3$
 Total volume = $954.26 \text{ ft}^3 + 31.81 \text{ ft}^3 = 986.07 \text{ ft}^3$

ANSWER KEYS

- 14) radius = diameter \div 2 = $1.25 \div 2 = 0.63$ m
Volume of cylinder = $\pi r^2 h = \pi \times (0.63 \text{ m})^2 \times 10 \text{ m} = 12.47 \text{ m}^3$
Volume of sphere = $\frac{\pi d^3}{6} = \frac{\pi \times (1.25 \text{ m})^3}{6} = \frac{6.14 \text{ m}^3}{6} = 1.02 \text{ m}^3$
Total volume = $12.47 \text{ m}^3 + 1.02 \text{ m}^3 = 13.49 \text{ m}^3$
- 15) radius = diameter \div 2 = $10.5 \div 2 = 5.25$ ft
Volume of cylinder = $\pi r^2 h = \pi \times (5.25 \text{ ft})^2 \times 27 \text{ ft} = 2337.93 \text{ ft}^3$
Volume of sphere = $\frac{\pi d^3}{6} = \frac{\pi \times (10.5 \text{ ft})^3}{6} = \frac{3\,636.79 \text{ ft}^3}{6} = 606.13 \text{ ft}^3$
Volume of half a sphere = $606.13 \text{ ft}^3 \div 2 = 303.07 \text{ ft}^3$
Total volume = $2\,337.93 \text{ ft}^3 + 303.07 \text{ ft}^3 = 2\,641 \text{ ft}^3$

Page 192, **Calculating the height or diameter when you know the volume**

- 1) $V = LWH$
 $36 \text{ yd}^3 = 3 \text{ yd} \times 1.5 \text{ yd} \times h$
 $36 \text{ yd}^3 = 4.5 \text{ yd}^2 \times h$
 $\frac{36 \text{ yd}^3}{4.5 \text{ yd}^2} = h$
 $8 \text{ yd} = h$
- 2) $V = LWH$
 $18 \text{ m}^3 = 3.6 \text{ m} \times W \times 2.1 \text{ m}$
 $18 \text{ m}^3 = 7.56 \text{ m}^2 \times W$
 $\frac{18 \text{ m}^3}{7.56 \text{ m}^2} = W$
 $2.38 \text{ m} = h$
- 3) $V = \pi r^2 h$
 $67 \text{ ft}^3 = \pi \times r^2 \times 6.5 \text{ ft}$
 $67 \text{ ft}^3 = 20.42 \text{ ft} \times r^2$
 $\frac{67 \text{ ft}^3}{20.42 \text{ ft}} = r^2$
 $3.28 \text{ ft}^2 = r^2$
 $\sqrt{3.28 \text{ ft}^2} = r$
 $1.81 \text{ ft} = r$

$$4) V = \pi r^2 h$$

$$188 \text{ in}^3 = \pi \times (22 \text{ in})^2 \times h$$

$$188 \text{ in}^3 = 1\,520.53 \text{ in}^2 \times h$$

$$\frac{188 \text{ in}^3}{1\,520.53 \text{ in}^2} = h$$

$$0.12 \text{ in} = h$$

$$5) V = \pi r^2 h$$

$$450 \text{ cm}^3 = \pi \times r^2 \times 224 \text{ cm}$$

$$450 \text{ cm}^3 = 703.72 \text{ cm} \times r^2$$

$$\frac{450 \text{ cm}^3}{703.72 \text{ cm}} = r^2$$

$$0.64 \text{ cm} = r^2$$

$$\sqrt{0.64 \text{ cm}} = r$$

$$0.8 \text{ cm} = r$$

$$d = 0.8 \text{ cm} \times 2 = 1.6 \text{ cm}$$

$$6) V = \frac{\pi r^2 h}{3}$$

$$234 \text{ ft}^3 = \frac{\pi \times (10 \text{ ft})^2 \times h}{3}$$

$$234 \text{ ft}^3 = \frac{314.16 \text{ ft}^2 \times h}{3}$$

$$234 \text{ ft}^3 \times 3 = 314.16 \text{ ft}^2 \times h$$

$$\frac{702 \text{ ft}^3}{314.16 \text{ ft}^2} = h$$

$$2.23 \text{ ft} = h$$

$$7) V = \frac{\pi r^2 h}{3}$$

$$234 \text{ ft}^3 = \frac{\pi \times r^2 \times 15.5 \text{ ft}}{3}$$

$$234 \text{ ft}^3 = \frac{48.7 \text{ ft} \times r^2}{3}$$

$$234 \text{ ft}^3 \times 3 = 48.7 \text{ ft} \times r^2$$

$$\frac{702 \text{ ft}^3}{48.7 \text{ ft}} = r^2$$

$$14.41 \text{ ft} = r^2$$

$$\sqrt{14.41 \text{ ft}} = r$$

$$3.8 \text{ ft} = r$$

$$\text{diameter} = \text{radius} \times 2 = 3.8 \times 2 = 7.6 \text{ ft}$$

Page 194, **Practice**

- 1) $1 \text{ ft} = 0.33 \text{ yd}$
 $V = LWH = 6 \text{ yd} \times 3 \text{ yd} \times 0.33 \text{ yd} = 5.94 \text{ yd}^3 = 6 \text{ yd}^3$
- 2) $400 \text{ mm} = 0.4 \text{ m}$
 $V = LWH = 3 \text{ m} \times 0.4 \text{ m} \times 12 \text{ m} = 14.4 \text{ m}^3 = 15 \text{ m}^3$
- 3) $V = LWH = 13 \text{ m} \times 6 \text{ m} \times 0.3 \text{ m} = 23.4 \text{ m}^3 = 24 \text{ m}^3$
- 4) $V = LWH = 5.5 \text{ ft} \times 2 \text{ ft} \times 3.6 \text{ ft} = 39.6 \text{ ft}^3$
 $27 \text{ ft}^3 = 1 \text{ yd}^3$
 $39.6 \text{ ft}^3 \div 27 \text{ ft}^3 = 1.47 \text{ yd}^3$
 $1.47 \text{ yd}^3 \times 0.3 = 0.44 \text{ yd}^3$
 Total volume of fill required = $1.47 \text{ yd}^3 + 0.44 \text{ yd}^3 = 1.91 \text{ yd}^3 = 2 \text{ yd}^3$
- 5) radius = diameter $\div 2 = 6.5 \text{ m} \div 2 = 3.25 \text{ m}$
 $V = \frac{\pi r^2 h}{3}$
 $V = \frac{\pi \times (3.25 \text{ m})^2 \times 2.3 \text{ m}}{3}$
 $V = \frac{76.32 \text{ m}^3}{3}$
 $V = 25.44 \text{ m}^3 = 26 \text{ m}^3$
- 6) $V = LWH = 39 \text{ ft} \times 1.6 \text{ ft} \times 5 \text{ ft} = 312 \text{ ft}^3$
 $312 \text{ ft}^3 \div 27 \text{ ft}^3 = 11.56 \text{ yd}^3 = 12 \text{ yd}^3$
- 7) $V = \pi r^2 h$
 $V = \pi \times (0.4 \text{ m})^2 \times 4.5 \text{ m}$
 $V = 2.26 \text{ m}^3$
 Total volume = $2.26 \text{ m}^3 \times 8 = 18.08 \text{ m}^3 = 19 \text{ m}^3$
- 8) $24 \text{ in} = 2 \text{ ft}$
 $V = LWH = 2 \text{ ft} \times 2 \text{ ft} \times 2 \text{ ft} = 8 \text{ ft}^3$
 Total volume = $8 \text{ ft}^3 \times 9 = 72 \text{ ft}^3$
 $72 \text{ ft}^3 \div 27 \text{ ft}^3 = 2.67 \text{ yd}^3 = 3 \text{ m}^3$

9)

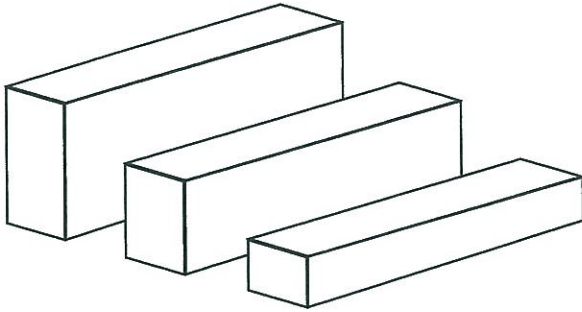

$$7\frac{1}{2}'' = 0.625'$$

$$V = LWH = 4.5 \text{ ft} \times 1 \text{ ft} \times 1.88 \text{ ft} = 8.46 \text{ ft}^3$$

$$V = LWH = 4.5 \text{ ft} \times 1 \text{ ft} \times 1.255 \text{ ft} = 5.65 \text{ ft}^3$$

$$V = LWH = 4.5 \text{ ft} \times 1 \text{ ft} \times 0.63 \text{ ft} = 2.84 \text{ ft}^3$$

$$\text{Total volume} = 8.46 \text{ ft}^3 + 5.65 \text{ ft}^3 + 2.84 \text{ ft}^3 = 16.95 \text{ ft}^3$$

$$16.95 \text{ ft}^3 \div 27 = 0.63 \text{ yd}^3 = 1 \text{ yd}^3$$

$$10) \quad V = LWH = 9 \text{ ft} \times 15 \text{ ft} \times 6.4 \text{ ft} = 864 \text{ ft}^3$$

$$\text{Allowance for compaction} = 864 \text{ ft}^3 \times 0.25 = 216 \text{ ft}^3$$

$$\text{Total fill needed} = 864 \text{ ft}^3 + 216 \text{ ft}^3 = 1\,080 \text{ ft}^3$$

$$V = \frac{\pi r^2 h}{3} = \frac{\pi \times (6 \text{ ft})^2 \times 7 \text{ ft}}{3} = \frac{791.68}{3} = 263.89 \text{ ft}^3$$

$$\text{Allowance for compaction} = 263.89 \text{ ft}^3 \times 0.25 = 65.97 \text{ ft}^3$$

$$\text{Total fill available} = 263.89 \text{ ft}^3 - 65.97 \text{ ft}^3 = 197.92 \text{ ft}^3$$

The contractor needs to order more fill =

$$1\,080 \text{ ft}^3 - 197.92 \text{ ft}^3 = 882.08 \text{ ft}^3$$

$$882.08 \text{ ft}^3 \div 27 = 32.67 \text{ yd}^3 = 33 \text{ yd}^3$$

11) The side of the pool is a trapezoid. Use the side as the base.

$$\text{area of base} = \left(\frac{b_1 + b_2}{2} \right) h = \left(\frac{3 + 12}{2} \right) 80 = 7.5 \times 80 = 600 \text{ ft}^2$$

$$\text{volume of pool} = \text{area of base} \times h = 600 \text{ ft}^2 \times 25 \text{ ft} = 15\,000 \text{ ft}^3$$

$$15\,000 \text{ ft}^3 \div 27 \text{ ft}^3 = 555.56 \text{ yd}^3$$

$$555.56 \text{ yd}^3 \div 27 \text{ yd}^3 = 20.6 = 21$$

There are 21 truckloads.

12) Volume of big rectangular solid = LWH =

$$145 \text{ ft} \times 75 \text{ ft} \times 8.5 \text{ ft} = 92\,437.5 \text{ ft}^3$$

Volume of small rectangular solid = LWH =

$$65 \text{ ft} \times 40 \text{ ft} \times 8.5 \text{ ft} = 22\,100 \text{ ft}^3$$

$$\text{Total volume} = 92\,437.5 \text{ ft}^3 - 22\,100 \text{ ft}^3 = 70\,337.5 \text{ ft}^3$$

$$70\,337.5 \text{ ft}^3 \div 27 \text{ ft}^3 = 2\,605.1 \text{ yd}^3$$

$$2\,605.1 \text{ yd}^3 \div 27 \text{ yd}^3 = 96.49 = 97 \text{ truckloads}$$