

RIGHT-ANGLE TRIANGLES

Trades workers often use the 3:4:5 Method, Pythagorean Theorem and trigonometry. The 3:4:5 Method is used to calculate the length of a missing side when the length of two sides is known and to check if corners are square. The Pythagorean Theorem is used to calculate the third side of a right-angle triangle when the length of two sides is known. Trigonometry is used to lay out job sites, to calculate the lengths and heights of things when direct measurements cannot be taken and to calculate the size of angles.

When you have finished this section you will be able to:

- Define and recognise common angles.
- Calculate the size of the missing angle in a triangle.
- Add and subtract degrees, minutes and seconds.
- Use the 3:4:5 Rule (Pythagorean Theorem) to calculate the length of the missing side in a right angle triangle.
- Locate opposite and adjacent sides in reference to a specific angle.
- Calculate the length of a side when an angle and one side are known.
- Calculate an angle when two sides are known.
- Solve word problems using the 3:4:5 Method and trigonometry.
- Solve applications using the 3:4:5 Method and trigonometry.

ANGLES

An angle is formed when two straight lines meet to form a corner. This corner is called the vertex.

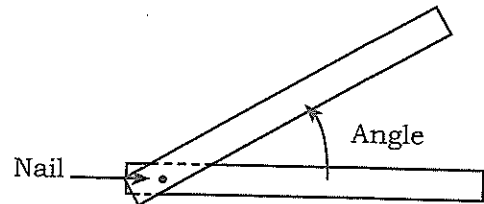
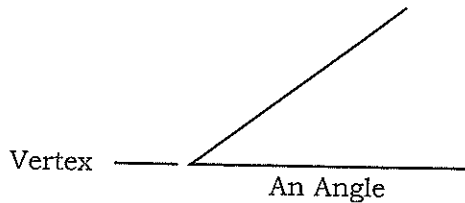

An angle describes how much something turns or rotates. For example, if you put a nail through a board, and then rotate the board around the nail, you could say the board turned through an angle.

The amount of turning is the size of the angle. Angles are measured in degrees. An angle of forty-five degrees is written as 45° .

Protractors, steel squares, transits, or special triangles are used in construction to find the number of degrees in an angle.

Basic Angles

You should be able to identify the angles below and use that information to solve other problems.

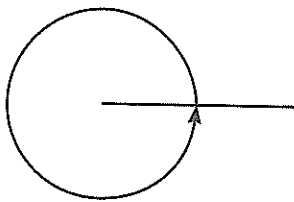

One full turn = 360°



One half turn = 180°

Note: also called a straight angle

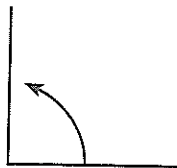

One quarter turn = 90°

Note: also called a right angle

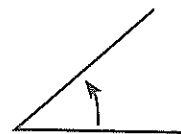

One eighth turn = 45°

Intersecting Lines, Opposite Angles and Parallel Lines

- When 2 lines intersect or cross, the opposite angles are equal.

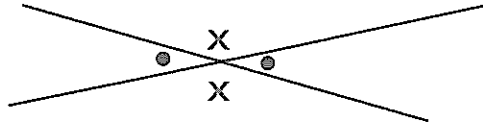

- Two straight lines are parallel when they run in exactly the same direction and do not cross at any point.

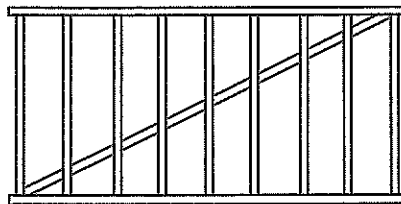

- If 2 parallel lines are crossed by a third line, the angles between the parallel lines that are diagonal to each other are equal. The third line is called a transversal.

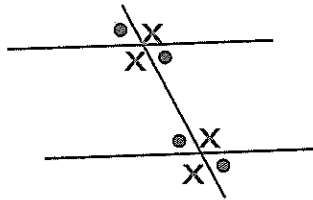

Labelling Angles in Triangles

All triangles have three angles. To be able to identify a specific angle in the triangle, the angles need to be labelled or named. Angles can be labelled:

- by number - $\angle 3$

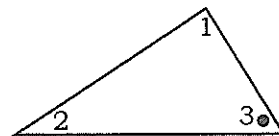

- by a single letter - $\angle B$

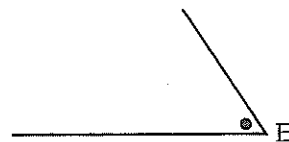

- by letters - $\angle ABC$

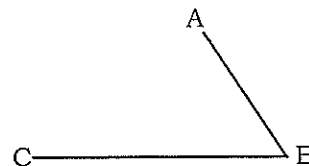

RIGHT-ANGLE TRIANGLES

Answer the following questions about triangles.

- 1) Look at the triangle. Write the two other ways the angle can be named.

- a) $\angle 2$
- b) $\angle XYZ$
- c) $\angle 3$
- d) $\angle 1$

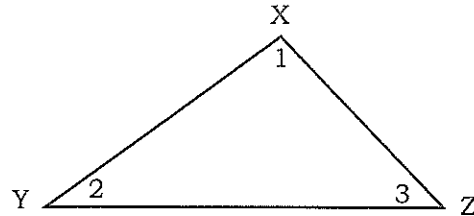

- 2) Calculate the number of degrees in each of the following.

- a) $\angle 7 + \angle 8 + \angle 9 =$
- b) $\angle 8 + \angle 9 + \angle 10 =$
- c) $\angle 11 + \angle 7 =$
- d) $\angle 7 + \angle 8 + \angle 9 + \angle 10 + \angle 11 =$

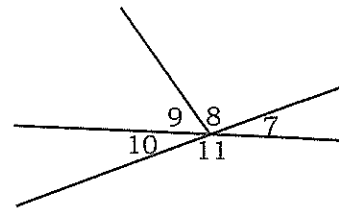

- 3) Write in the number of degrees in each of the marked angles.

a)

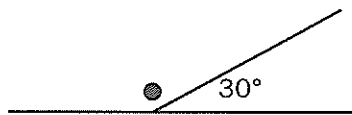

b)

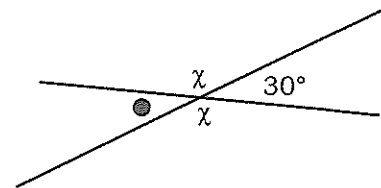

c)

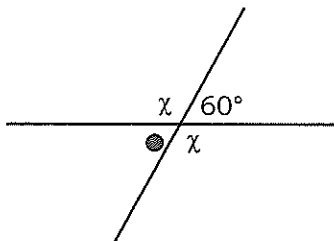

d)

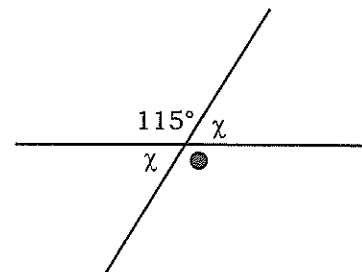

4) Write the number of degrees in each of the following named angles.

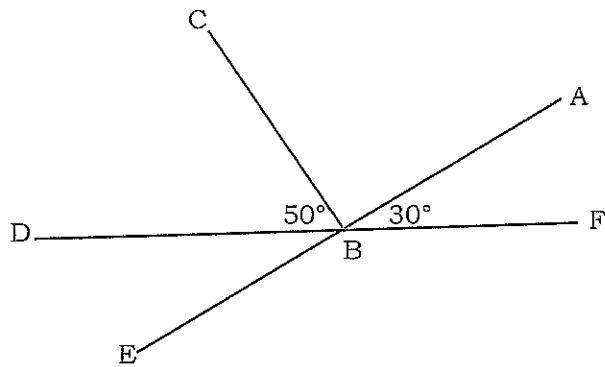

Hint:

 means 90°

- a) $\angle DBE =$
- b) $\angle FBD =$
- c) $\angle ABF + \angle ABC + \angle CBD =$
- d) $\angle ABC =$
- e) $\angle ABC + \angle CBD =$
- f) $\angle ABC + \angle CBD + \angle FBE =$

Calculating the Missing Angle in a Triangle

If two angles in a triangle are known, the third can be easily calculated. The three angles in a triangle always add up to 180°.

$$\angle 1 + \angle 2 + \angle 3 = 180^\circ$$

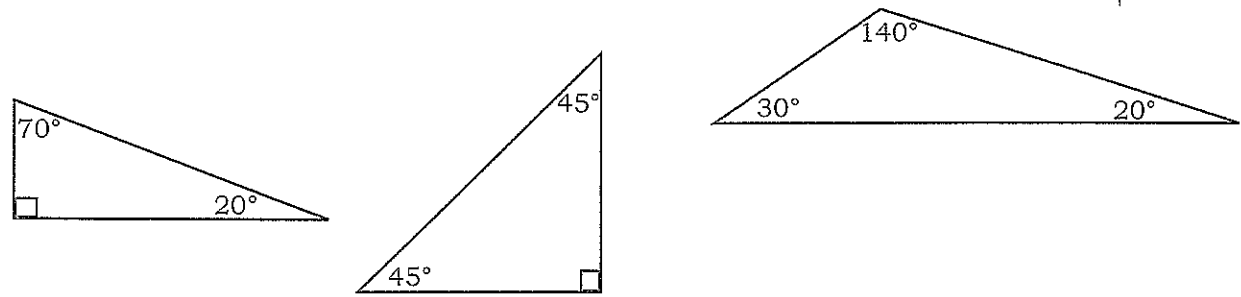

RIGHT-ANGLE TRIANGLES

Calculate the missing angle in each of the following triangles.

1)

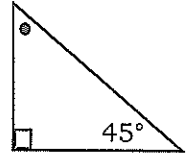

2)

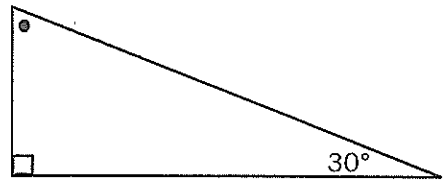

3)

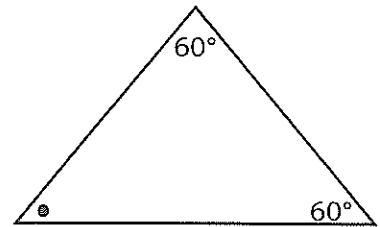

4)

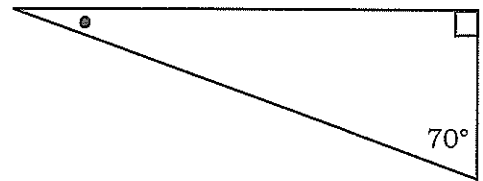

5)

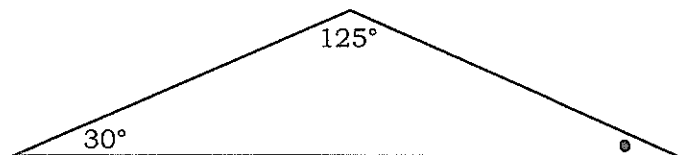

RIGHT-ANGLE TRIANGLES

6)

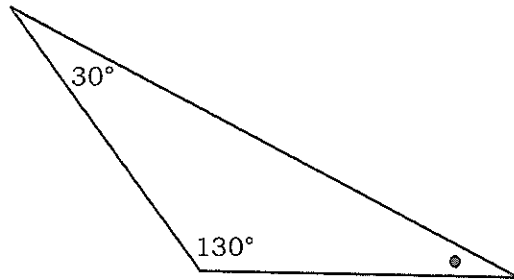

7)

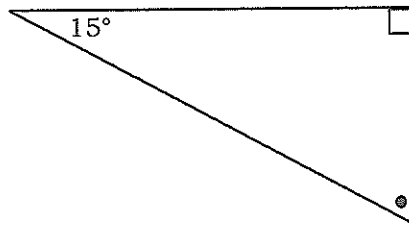

8)



9)

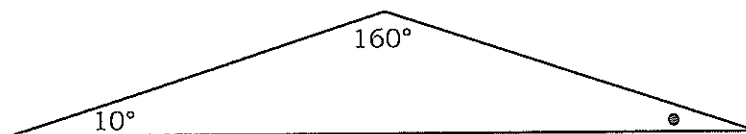

10)

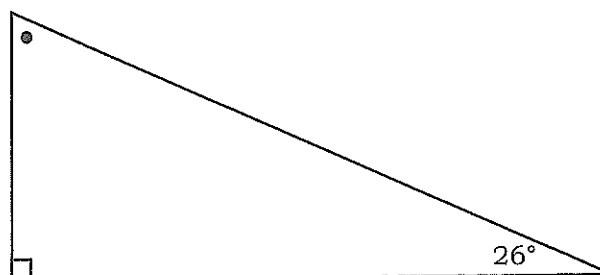

RIGHT-ANGLE TRIANGLES

Calculating Degrees, Minutes and Seconds

Angles are measured in degrees (degrees of arc), minutes (minutes of arc) and seconds (seconds of arc). When you are surveying or working with a transit on a job site, you will need to use units that are smaller than 1° .

Hint:

The symbol for degrees is $^\circ$.
The symbol for minutes is $'$.
The symbol for seconds is $"$.

$$60" \text{ (seconds)} = 1' \text{ (minute)}$$

$$60' \text{ (minutes)} = 1^\circ \text{ (degree)}$$

$$3600" \text{ (seconds)} = 1^\circ \text{ (degree)}$$

Hint: Even though the symbols for seconds and minutes are the same as the symbols for inches and feet, and the words 'seconds' and 'minutes' are used for time measurement, there shouldn't be any confusion. It should be clear from the situation if you are talking about angle measurement, length measurement, or time measurement.

Example 1:

Change $65"$ to minutes and seconds.

$$65" = 60" + 5" = 1' + 5" = 1' 5"$$

Example 2:

Change $152'$ to degrees and minutes.

$$\begin{array}{r} 2 \\ 60 \overline{)152} \\ \underline{-120} \\ 32 \end{array}$$

$$152' = 2^\circ 32'$$

Change the following seconds to minutes and seconds.

- 1) a) $61"$ b) $119"$ c) $72"$ d) $112"$
- 2) a) $180"$ b) $183"$ c) $77"$ d) $242"$

Change the following minutes to degrees and minutes.

- 1) a) 61' b) 119' c) 47' d) 80'
- 2) a) 110' b) 95' c) 255' d) 60'

Adding and Subtracting Angles

Example 1:

		$\begin{array}{r} 23^\circ \quad 14' \quad 32'' \\ + 12^\circ \quad 55' \quad 41'' \\ \hline \end{array}$
Step 1:	Add the seconds.	$\begin{array}{r} 23^\circ \quad 14' \quad 32'' \\ + 12^\circ \quad 55' \quad 41'' \\ \hline \quad 73'' \end{array}$
Step 2:	Add the minutes.	$\begin{array}{r} 23^\circ \quad 14' \quad 32'' \\ + 12^\circ \quad 55' \quad 41'' \\ \hline \quad 69' \quad 73'' \end{array}$
Step 3:	Add the degrees.	$\begin{array}{r} 23^\circ \quad 14' \quad 32'' \\ + 12^\circ \quad 55' \quad 41'' \\ \hline 35^\circ \quad 69' \quad 73'' \end{array}$
Step 4:	Simplify any seconds or minutes amount that is larger than 60.	
		$73'' = 1' 13''$
	Convert the seconds.	$\begin{array}{r} 35^\circ \quad 69' \quad \boxed{73''} \\ \quad \downarrow \\ \quad 1' 13'' \end{array}$
		$\begin{array}{r} 35^\circ \quad \boxed{70'} \quad 13'' \\ \quad \downarrow \\ \quad 1^\circ 10' \end{array}$
	Convert the minutes.	$36^\circ 10' 13''$

RIGHT-ANGLE TRIANGLES

Remember:

1' = 60"

1° = 60'

Add the following.

$$1) \begin{array}{r} 24^\circ 19' 32'' \\ + 18^\circ 32' 16'' \\ \hline \end{array}$$

$$2) \begin{array}{r} 4^\circ 0' 42'' \\ + 5^\circ 2' 8'' \\ \hline \end{array}$$

$$3) \begin{array}{r} 71^\circ 14' 28'' \\ + 5^\circ 18' 51'' \\ \hline \end{array}$$

$$4) \begin{array}{r} 77^\circ 45' 54'' \\ + 28^\circ 6' 17'' \\ \hline \end{array}$$

$$5) \begin{array}{r} 85^\circ 51' 15'' \\ + 4^\circ 8' 45'' \\ \hline \end{array}$$

$$6) \begin{array}{r} 42^\circ 45' 19'' \\ + 5^\circ 27' 52'' \\ \hline \end{array}$$

$$7) \begin{array}{r} 41^\circ 45' 19'' \\ + 35^\circ 14' 38'' \\ \hline \end{array}$$

$$8) \begin{array}{r} 74^\circ 0' 51'' \\ + 19^\circ 0' 42'' \\ \hline \end{array}$$

$$9) \begin{array}{r} 26^\circ 32' 0'' \\ + 45^\circ 47' 0'' \\ \hline \end{array}$$

$$10) \begin{array}{r} 15^\circ 57' 21'' \\ + 18^\circ 44' 41'' \\ \hline \end{array}$$

$$11) \begin{array}{r} 55^\circ 44' 11'' \\ + 88^\circ 33' 22'' \\ \hline \end{array}$$

$$12) \begin{array}{r} 89^\circ 59' 59'' \\ + 90^\circ 0' 1'' \\ \hline \end{array}$$

$$13) \begin{array}{r} 96^\circ 19' \\ + 152^\circ 21' \\ \hline \end{array}$$

$$14) \begin{array}{r} 32^\circ 43' 14'' \\ + 47^\circ 17' 58'' \\ \hline \end{array}$$

$$15) \begin{array}{r} 179^\circ 58' 56'' \\ + \quad \quad 1' 4'' \\ \hline \end{array}$$

$$16) \begin{array}{r} 21^\circ 46' 34'' \\ + 18^\circ 21' 27'' \\ \hline \end{array}$$

Subtracting Angles

Example 1:

		$\begin{array}{r} 45^\circ 16' 39'' \\ - 22^\circ 3' 13'' \\ \hline \end{array}$
Step 1:	Subtract the seconds.	$\begin{array}{r} 45^\circ 16' 39'' \\ - 22^\circ 3' 13'' \\ \hline 26'' \end{array}$
Step 2:	Subtract the minutes.	$\begin{array}{r} 45^\circ 16' 39'' \\ - 22^\circ 3' 13'' \\ \hline 13' 26'' \end{array}$
Step 3:	Subtract the degrees.	$\begin{array}{r} 45^\circ 16' 39'' \\ - 22^\circ 3' 13'' \\ \hline 23^\circ 13' 26'' \end{array}$

Borrowing

Example 2:

		$\begin{array}{r} 27^\circ 35' 12'' \\ - 13^\circ 11' 42'' \\ \hline \end{array}$
Step 1:	Subtract the seconds. You can't subtract 42 from 12 so borrow one from the minutes. Change 35 to 34. One minute equals 60 seconds. Add 60 to 12. Now subtract the seconds.	$\begin{array}{r} 27^\circ 35' 12'' \\ - 13^\circ 11' 42'' \\ \hline 27^\circ 34' 72'' \\ - 13^\circ 11' 42'' \\ \hline 30'' \end{array}$
Step 2:	Subtract the minutes.	$\begin{array}{r} 27^\circ 34' 72'' \\ - 13^\circ 11' 42'' \\ \hline 23' 30'' \end{array}$
Step 3:	Subtract the degrees.	$\begin{array}{r} 27^\circ 34' 72'' \\ - 13^\circ 11' 42'' \\ \hline 14^\circ 23' 30'' \end{array}$

Subtract the following.

1)
$$\begin{array}{r} 34^\circ 17' 45'' \\ - 16^\circ 5' 19'' \\ \hline \end{array}$$

2)
$$\begin{array}{r} 45^\circ 18' 55'' \\ - 22^\circ 19' 26'' \\ \hline \end{array}$$

3)
$$\begin{array}{r} 1^\circ 31' 15'' \\ - 30' 4'' \\ \hline \end{array}$$

4)
$$\begin{array}{r} 51^\circ 26' 19'' \\ - 18^\circ 12' 45'' \\ \hline \end{array}$$

5)
$$\begin{array}{r} 39^\circ 48' 15'' \\ - 27^\circ 32' 47'' \\ \hline \end{array}$$

6)
$$\begin{array}{r} 19^\circ 3' 17'' \\ - 4^\circ 21' 12'' \\ \hline \end{array}$$

7)
$$\begin{array}{r} 0^\circ 6' 8'' \\ - 0^\circ 5' 2'' \\ \hline \end{array}$$

8)
$$\begin{array}{r} 90^\circ 14' 28'' \\ - 17^\circ 18' 36'' \\ \hline \end{array}$$

9)
$$\begin{array}{r} 42^\circ 51' 18'' \\ - 31^\circ 59' 19'' \\ \hline \end{array}$$

10)
$$\begin{array}{r} 90^\circ 0' 0'' \\ - 21^\circ 42' 39'' \\ \hline \end{array}$$

11)
$$\begin{array}{r} 72^\circ 21' 17'' \\ - 71^\circ 59' 16'' \\ \hline \end{array}$$

12)
$$\begin{array}{r} 36^\circ 24' 56'' \\ - 18^\circ 12' 28'' \\ \hline \end{array}$$

13)
$$\begin{array}{r} 56^\circ 59' 1'' \\ - 45^\circ 1' 59'' \\ \hline \end{array}$$

14)
$$\begin{array}{r} 45^\circ 0' 12'' \\ - 22^\circ 0' 13'' \\ \hline \end{array}$$

15)
$$\begin{array}{r} 27^\circ 40' 0'' \\ - 18^\circ 51' 9'' \\ \hline \end{array}$$

16)
$$\begin{array}{r} 161^\circ 14' \\ - 98^\circ 12' \\ \hline \end{array}$$

USING THE PYTHAGOREAN THEOREM AND TRIGONOMETRY

Both Pythagorean Theorem and trigonometry work with right-angle triangles. It is important to remember:

- All right-angle triangles have three sides: hypotenuse, opposite and adjacent. In the trades, the sides are often called travel, rise and run.
- One angle in a right-angle triangle is always 90° .
- The sum of the three angles in a triangle is always equal to 180° .
- The travel (hypotenuse) is always the longest side and is opposite the right angle (90°).
- The opposite and adjacent sides (rise and run) change depending on which angle you are working from.

Pythagorean Theorem

Workers in the construction trades commonly refer to the Pythagorean Theorem as the 3:4:5 Method. The right triangle with sides measuring 3 feet, 4 feet and 5 feet (or 3, 4, and 5 of any other unit) easily demonstrates the idea behind this theorem:

If you multiply the length of each short side by itself, and add the two answers, the total is the length of the last side multiplied by itself.

$$(3 \times 3) + (4 \times 4) = (5 \times 5).$$

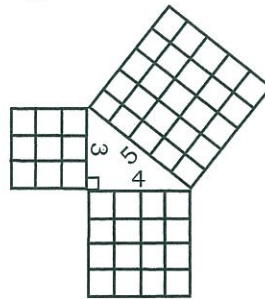

Although the theorem is often called the 3:4:5 Method, the math works for right triangles of any shape or size. This method is used in the construction industry to lay out the perimeters of buildings, to ensure corners are square, and to calculate the length of rafters and stringers on stairs. Plumbers use this method to calculate lengths of pipes in piping systems. Crane operators and riggers use it to calculate the length of the boom and the length of slings used to lift loads.

The basic formula is:

$$c^2 = a^2 + b^2$$

$$a^2 = c^2 - b^2$$

$$b^2 = c^2 - a^2$$

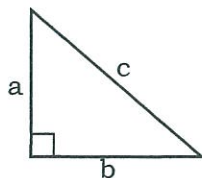

Hint:

 means a right angle.

Hint:

"c" is always the hypotenuse.

Hint:

The perpendicular sides of a right triangle are also called the legs.

In the construction trades, the sides are often referred to as the travel, the rise and the run.

$$\begin{aligned} \text{travel}^2 &= \text{rise}^2 + \text{run}^2 \\ \text{rise}^2 &= \text{travel}^2 - \text{run}^2 \\ \text{run}^2 &= \text{travel}^2 - \text{rise}^2 \end{aligned}$$

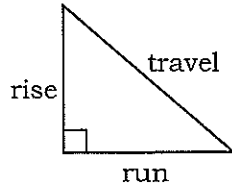

$$\begin{aligned} c^2 &= a^2 + b^2 \\ c^2 &= 3^2 + 4^2 \\ c^2 &= 9 + 16 \\ c^2 &= 25 \\ c &= 5 \end{aligned}$$

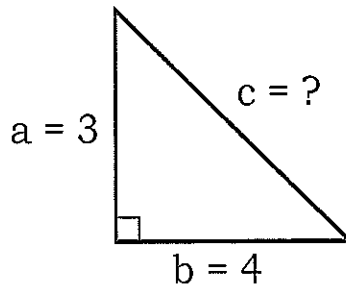

Sometimes you know the travel and need to calculate either the rise or the run.

$$\begin{aligned} b^2 &= c^2 - a^2 \\ b^2 &= 5^2 - 3^2 \\ b^2 &= 25 - 9 \\ b^2 &= 16 \\ b &= \sqrt{16} = 4 \end{aligned}$$

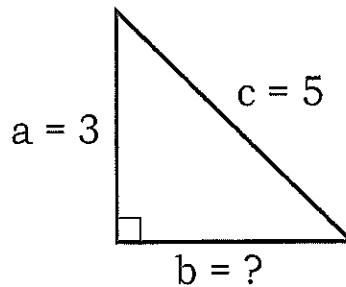

To calculate the rise use:

$$\begin{aligned} a^2 &= c^2 - b^2 \\ a^2 &= 5^2 - 4^2 \\ a^2 &= 25 - 16 \\ a^2 &= 9 \\ a &= \sqrt{9} = 3 \end{aligned}$$

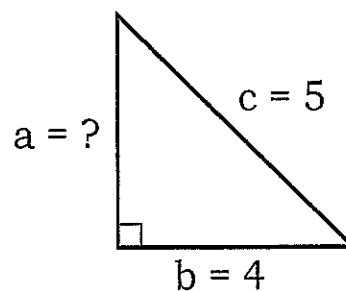

RIGHT-ANGLE TRIANGLES

Calculate the length of the missing side in the following right angle triangles. Round off answers to two decimal places.

- 1) rise = 1.8 m
run = 2.7 m

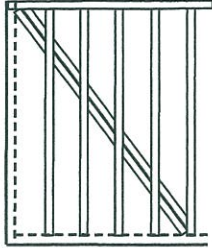

- 2) rise = 7' - 0"
run = 11' - 0"

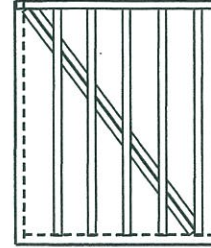

- 3) rise = 2.5 m
travel = 15.3 m

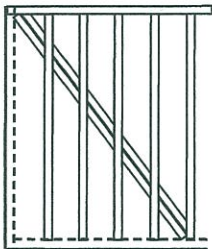

- 4) run = 16' - 0"
travel = 20'

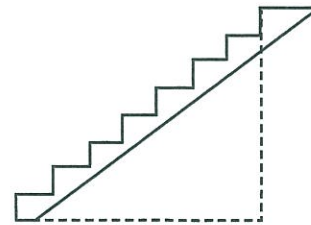

- 5) travel = 62 267 mm
total run = 2 900 mm

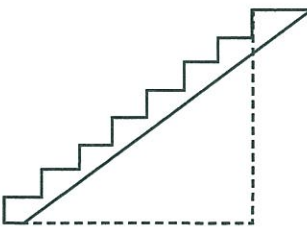

- 6) total rise = 1 000 mm
total run = 2 455 mm

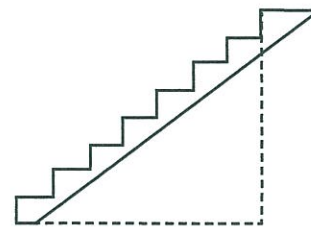

- 7) run = 4 236 mm
total rise = 1 955 mm
overhang = 850 mm

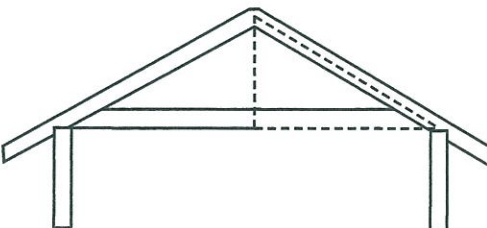

- 8) run = 1 829 mm
total rise = 1 355 mm
overhang = 305 mm

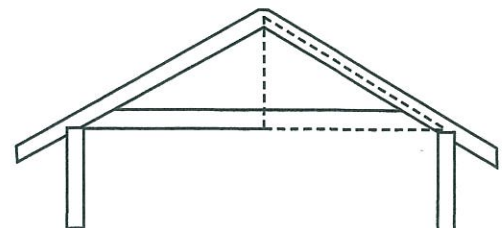

- 9) run = 2 400 mm
total rise = 1 500 mm
overhang = 350 mm

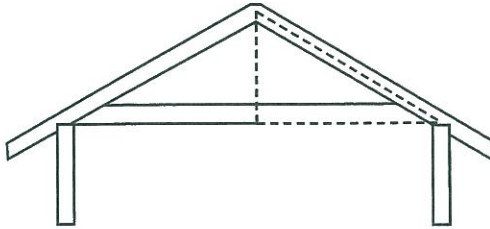

- 10) run = 6 875 mm
total rise = 3 658 mm
overhang = 875 mm

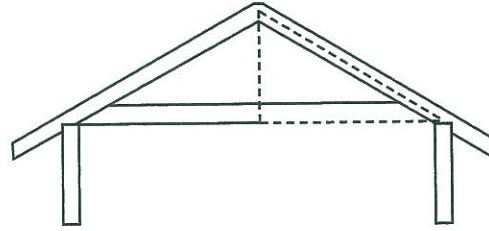

TRIGONOMETRY

You must know at least two values in order to solve angles or lengths of a right angle triangle. You can solve a right-angle triangle if you know

- the length of two of the sides
- one of the angles and the length of one of the sides

Remember: the hypotenuse (travel) is always the longest side and is always opposite the right angle.

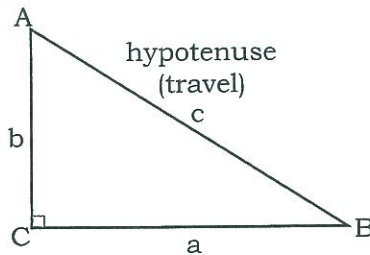

The opposite and adjacent sides of a right triangle change depending on which angle is used as the reference point. It is important to learn how to identify the sides in a right triangle because it will make trigonometry easier to understand.

If $\angle A$ is the reference point:

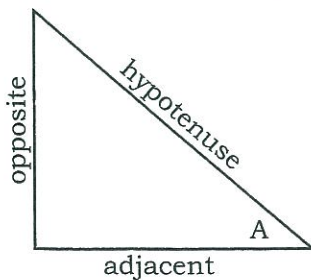

If $\angle B$ is the reference point:

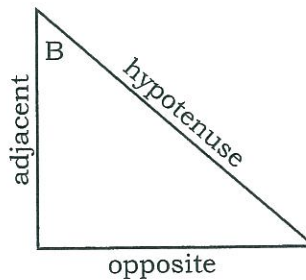

RIGHT-ANGLE TRIANGLES

Identify opposite and adjacent in the right angle triangles below using the identified angle as the reference point.

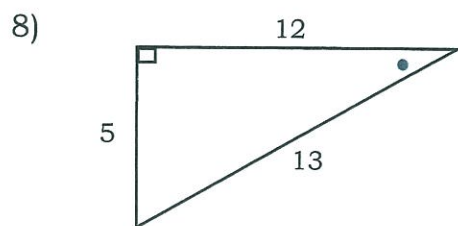
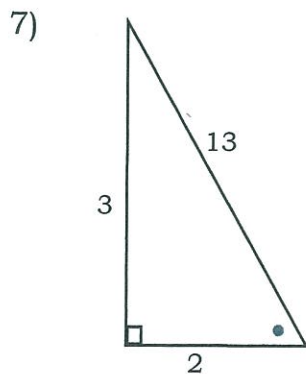
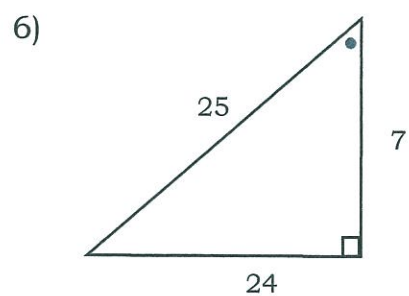
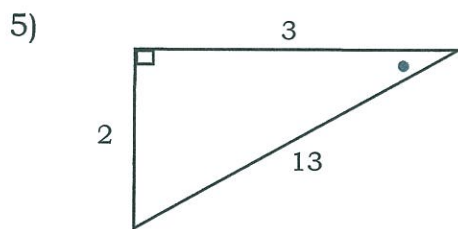
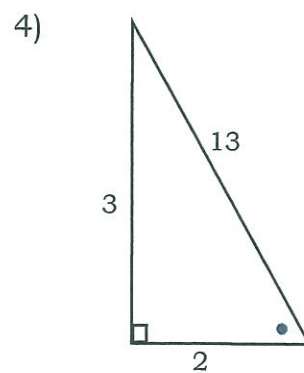
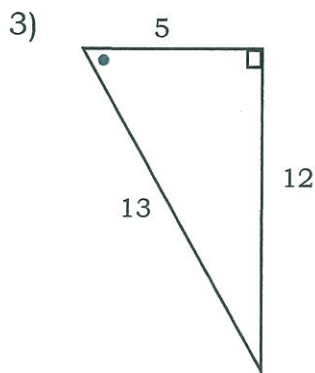
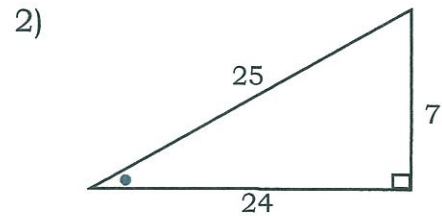
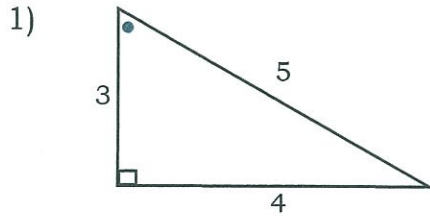

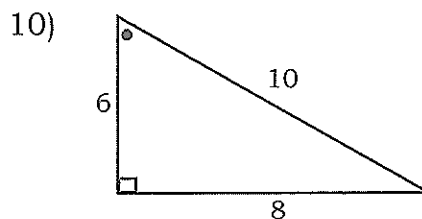
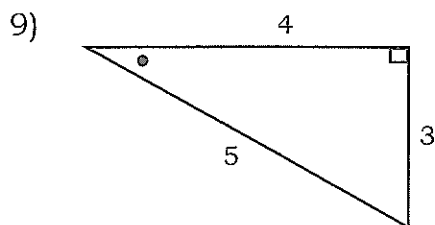

TRIGONOMETRIC RATIOS

Ratio describes the proportional relationship between two things. The three sides of a right-angle triangle hypotenuse, opposite and adjacent have a fixed relationship with each other. This means that as one of the three sides increases or decreases in length, the other two sides increase or decrease proportionately.

There are three basic trigonometric ratios: sine, cosine and tangent.

1. The sine of an angle is the ratio of the length of the opposite side to the length of the hypotenuse. The abbreviation of sine is "sin".

$$\sin = \frac{\text{opposite side}}{\text{hypotenuse}}$$

2. The cosine of an angle is the ratio of the length of the adjacent side to the length of the hypotenuse. The abbreviation of cosine is "cos".

$$\cos = \frac{\text{adjacent side}}{\text{hypotenuse}}$$

3. The tangent of an angle is the ratio of the length of the opposite side to the length of the adjacent side. The abbreviation of tangent is "tan".

$$\tan = \frac{\text{opposite side}}{\text{adjacent side}}$$

One way to remember these three trigonometric functions is: SOHCAHTOA.

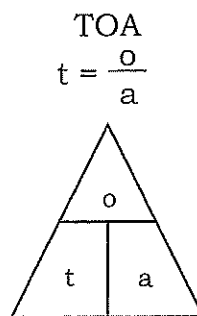
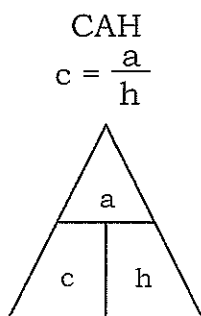
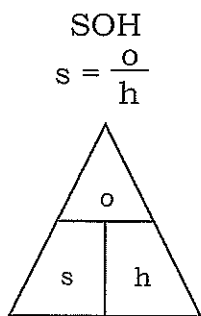

Using the triangles makes it easier to know when to multiply or divide.

Example:

Cover up the value you are asked to calculate with your finger.

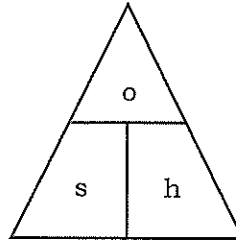

- ◆ If the two that remain are next to each other, you multiply them
opposite = $\sin \theta \times$ hypotenuse
- ◆ If you know one of the bottom corners, then divide the top corner by the other bottom corner.
 $\sin \theta = \text{opposite} \div \text{hypotenuse}$
 $\text{hypotenuse} = \text{opposite} \div \sin \theta$

Note:

θ is the Greek letter theta. It is used to represent the angle. $\sin \theta$ means the sine of angle theta.

Sine, cosine and tangent each have a reciprocal ratio: secant, cosecant and cotangent. These three trigonometric functions are not explained in this chapter because they are not commonly used by trades workers.

Calculating the Length of a Side

If you know an angle and the length of one of the sides, you can calculate the length of one of the other sides.

Example 1:

Calculate the length of the hypotenuse (travel).

Step 1: Draw a diagram and label it.

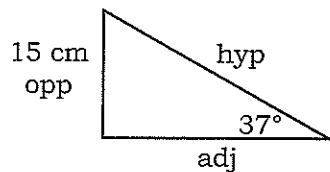

Label the diagram with the known information. Label the sides hypotenuse, opposite and adjacent.

Step 2: Write the trig ratio needed to solve the problem. Calculate the length of the hypotenuse. Use \sin because you know the length of the side opposite to the 37° angle.

$$\text{hypotenuse} = \frac{\text{opposite}}{\sin}$$

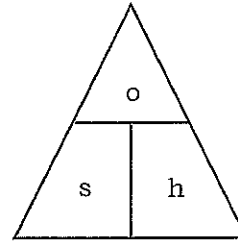

Step 3: Calculate the length of the side.

$$\text{hypotenuse} = \frac{\text{opposite}}{\sin} = \frac{15 \text{ cm}}{\sin 37^\circ} = 24.92 \text{ cm}$$

Note: Some calculators require the degrees to be entered before pressing the sin, cos or tan button. Other calculators require the sin, cos or tan button to be pressed before entering the degrees.

Example 2:

Calculate the length of the adjacent side.

Step 1: Draw a diagram and label it.

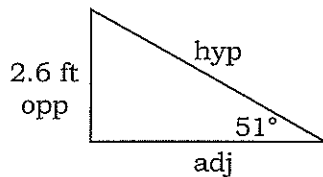

Label the diagram with the known information. Label the sides hypotenuse, opposite and adjacent.

Step 2: Write the trig ratio needed to solve the problem. Calculate the length of the adjacent side. Use tan because you know the length of the side opposite to the 51° angle.

$$\text{adjacent} = \frac{\text{opposite}}{\tan}$$

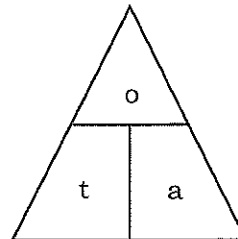

Step 3: Calculate the length of the side.

$$\text{adjacent} = \frac{\text{opposite}}{\tan} = \frac{2.6 \text{ ft}}{\tan 51^\circ} = 2.11 \text{ ft}$$

Hint:

Measurements must be in the same unit of measurement. Label the hypotenuse, opposite and adjacent sides.

RIGHT-ANGLE TRIANGLES

Calculate the length of the indicated side. Round off answers to two decimal places.

- 1) Calculate the length of the hypotenuse.

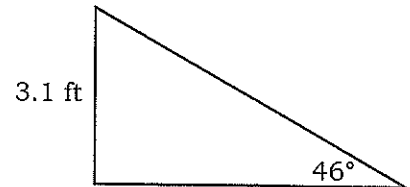

- 2) Calculate the length of the hypotenuse.

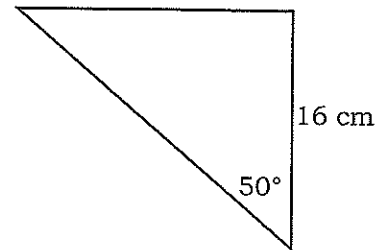

- 3) Calculate the length of the adjacent.

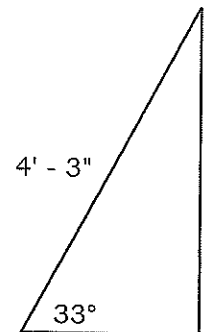

- 4) Calculate the length of the opposite.

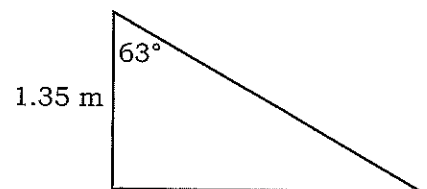

- 5) Calculate the length of the adjacent.

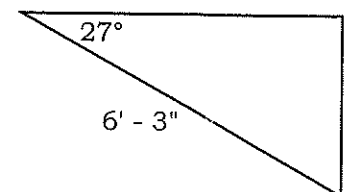

Hint

Refer to the chapter on Fractions for converting inches to decimals of a foot.

6) Calculate the length of the hypotenuse.

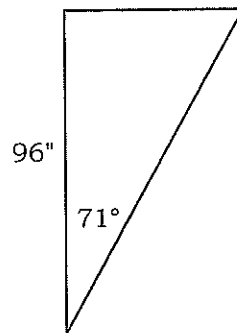

7) Calculate the length of the opposite.

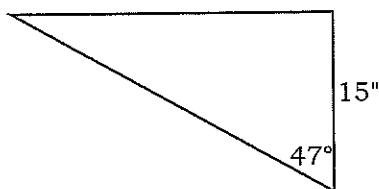

8) Calculate the length of the opposite.

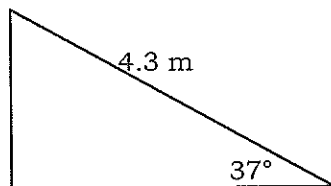

9) Calculate the length of the hypotenuse.

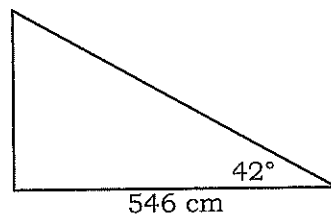

10) Calculate the length of the adjacent.

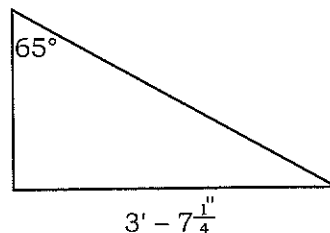

RIGHT-ANGLE TRIANGLES

Calculating the Size of an Angle

If you know the length of two of the sides, you can calculate an angle using trigonometry.

Hint:

If you know the length of two of the sides, you can use the Pythagorean Theorem to calculate the length of the third side.

Example 1:

Calculate the size of the angle indicated in the diagram.

Step 1: Draw a diagram and label it.

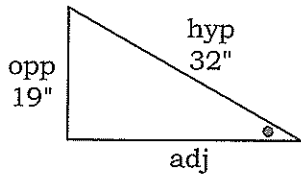

Label the diagram with the known information.
Label the sides hypotenuse, opposite and adjacent.

Step 2: Write the trig ratio needed to solve the problem.
Calculate the size of the angle marked with a dot.

Use sin because you know the length of the side opposite the angle that you are asked to solve and the length of the hypotenuse.

$$\sin = \frac{\text{opposite}}{\text{hypotenuse}}$$

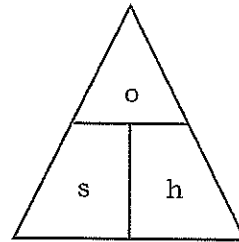

Step 3: Calculate the angle.

$$\sin = \frac{\text{opposite}}{\text{hypotenuse}} = \frac{19}{32} = 0.59375$$

Press 2nd function. Press sin.

$$= 36.42^\circ$$

Example 2:

Calculate the size of the angle indicated in the diagram.

Step 1: Draw a diagram and label it.

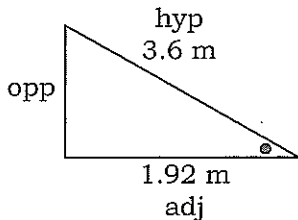

Label the diagram with the known information.
Label the sides hypotenuse, opposite and adjacent.

Step 2: Write the trig ratio needed to solve the problem.

$$\cos = \frac{\text{adjacent}}{\text{hypotenuse}}$$

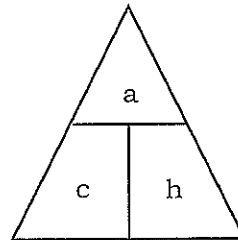

Calculate the size of the angle marked with a dot.

Use cos because you know the length of the side adjacent to the angle that you are asked to solve and the length of the hypotenuse.

Step 3: Calculate the angle.

$$\cos = \frac{\text{adjacent}}{\text{hypotenuse}} = \frac{1.92 \text{ m}}{3.6 \text{ m}} = 0.533333333$$

Press 2nd function. Press cos.

$$= 57.77^\circ$$

RIGHT-ANGLE TRIANGLES

Calculate the size of the angle indicated. Round off answers to two decimal places.

1)

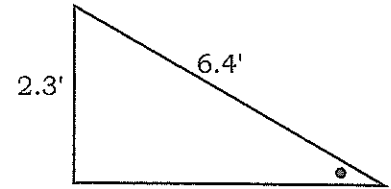

2)

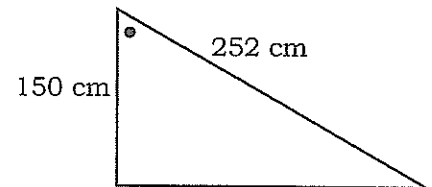

3)

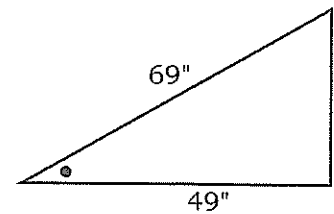

4)

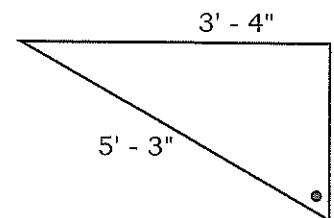

5)

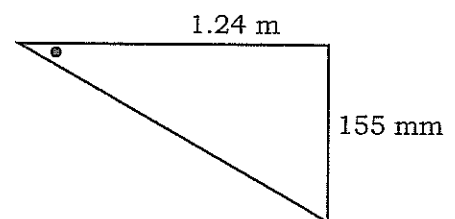

Hint:

Measurements must be in the same unit of measurement.

RIGHT-ANGLE TRIANGLES

6)

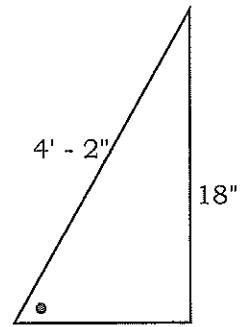

7)

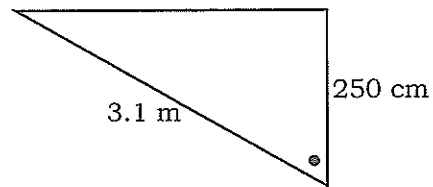

8)

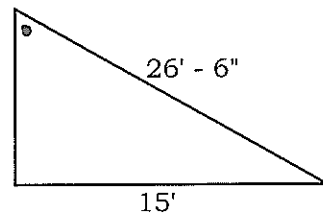

9)

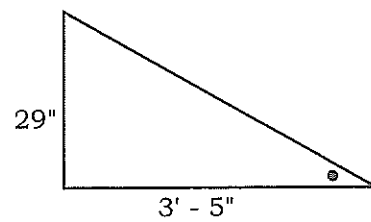

10)

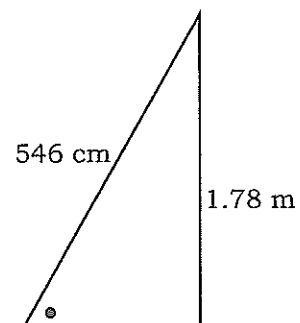

WORKING WITH MULTI-SIDED SHAPES

Sometimes the shape you are working with does not seem to have any right-angle triangles. You may need to draw on other information to solve the problem.

Example:

Calculate angle A and angle B, side b and side c.

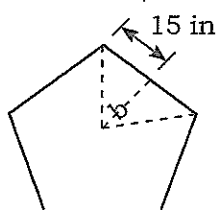

At first glance, it looks as if there is not enough information to solve the triangle because two pieces of information are needed to use trigonometry: the length of two of the sides, or the length of one side and the size of one of the angles. However, there is enough information to solve the triangle.

The shape has five equal sides and is called a pentagon.

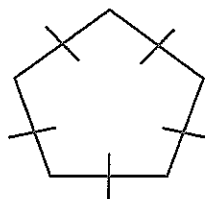

Because the sides are equal, five equal triangles are formed when lines are drawn from each of the five points to the centre of the pentagon.

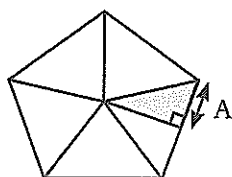

Pentagon

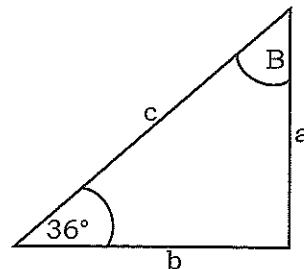

Divide each triangle in half by drawing a perpendicular line from the centre point to the base of the triangle. Now there are 10 equal-sized right-angle triangles.

- Calculate angle A.

There are 360° in one full turn – all the way around the centre point of the pentagon. Divide 360° by 10. The answer is the size of angle A.

$$\text{angle A} = 360^\circ \div 10 = 36^\circ$$

$$\text{side a} = 15 \text{ in}$$

- Calculate angle B.

$$90^\circ - 36^\circ = 54^\circ$$

- Calculate side b.

Use trigonometry. Label the sides opposite, adjacent and hypotenuse.

$$\text{angle A} = 36^\circ$$

$$\text{side a} = 15 \text{ in}$$

$$\text{adjacent} = \frac{\text{opposite}}{\tan} = \frac{15 \text{ in}}{\tan 36^\circ} = \frac{15 \text{ in}}{.0726542528} = 20.65 \text{ in}$$

$$\text{side b} = 20.65 \text{ in}$$

- Calculate side c.

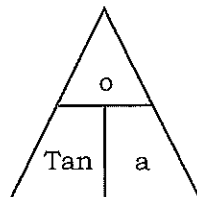
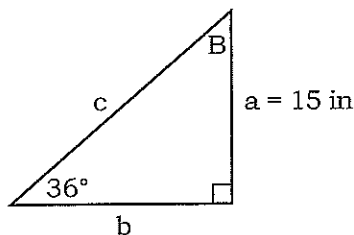
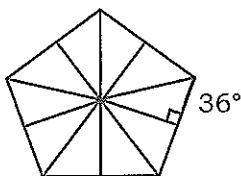

Use either trig or Pythagorean Theorem.

Using Trigonometry	Using Pythagorean Theorem
<p>Note: There are several ways to calculate side C using trig depending on which angle is used and which trig function.</p> $\text{hypotenuse} = \frac{\text{opposite}}{\sin} = \frac{15 \text{ in}}{\sin 36^\circ} = \frac{15 \text{ in}}{0.5878} = 25.52 \text{ in}$	$a^2 + b^2 = c^2$ $15^2 + 20.65^2 = c^2$ $225 + 426.42 = c^2$ $\sqrt{651.42} = c$ $25.52 \text{ in} = c$

RIGHT-ANGLE TRIANGLES

Solve the triangles in the following shapes.

1. angle A =

angle B =

side a =

side b = 20 ft

side c =

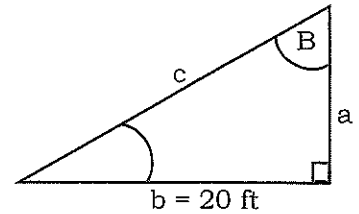
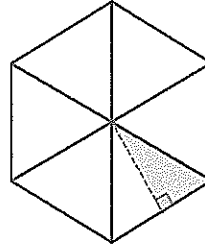

2. angle A =

angle B =

side a =

side b =

side c = 24 ft

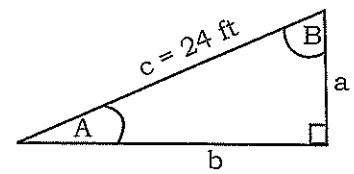
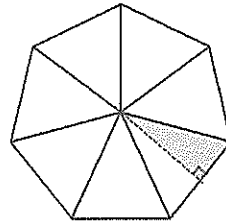

3. angle A =

angle B =

side a = 8 m

side b =

side c =

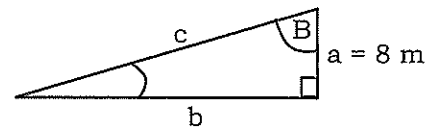
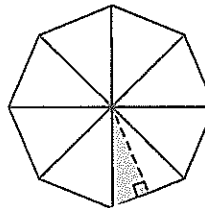

Hint:

Draw a diagram and label it with the known information.

PRACTICE

- 1) A foreman wants to know if two walls are perpendicular (90°) to each other. One wall is 5 ft long and the other wall is 12 ft long. What should the diagonal distance from corner to corner measure?

- 2) A carpenter wants to brace the top of an eight-foot wall to a peg 15' from the base of the wall. Calculate the length of the brace.

- 3) A brace 6.5 m long is used to stabilize a wall. If the brace is attached to the wall at a point 6 m up the wall, how far from the base must it be secured?

- 4) Calculate the diagonal length of the staircase below.

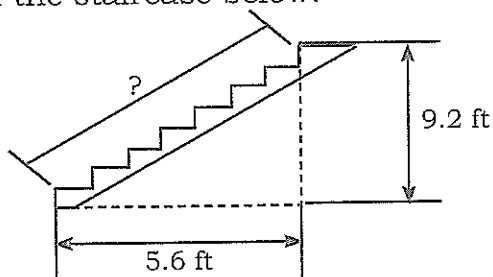

- 5) Calculate the length of the rafter needed in the diagram below. The overhang is 3 ft long.

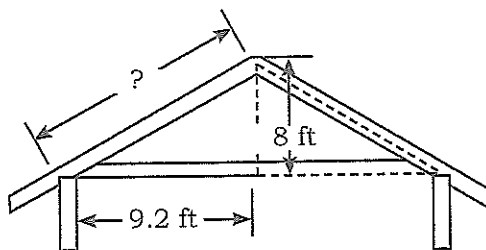

RIGHT-ANGLE TRIANGLES

- 6) Look at the diagram of the building lot below. The diagonal line measures 71.1 ft and the width is 46.6 ft. Calculate the length of the building lot.

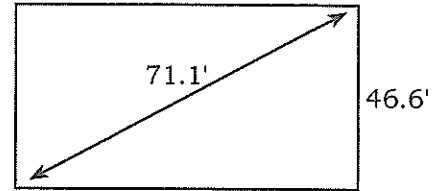

- 7) A ladder is leaning against a 15 ft wall at a 75° angle. The ladder must extend 3 ft over the wall according to Health and Safety Regulations. Calculate the length of ladder needed.

Hint:

Draw a diagram.

- 8) Calculate the length of the rafter in the diagram below.

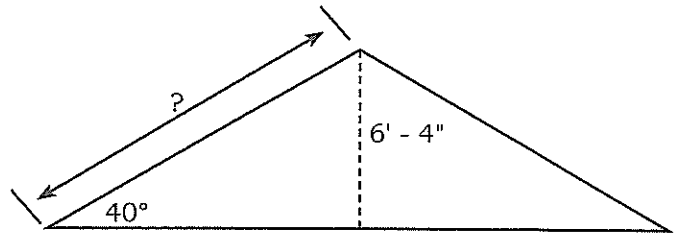

- 9) Calculate the length of the beams labelled x in the bridge truss shown below. The marked angle is 25° .

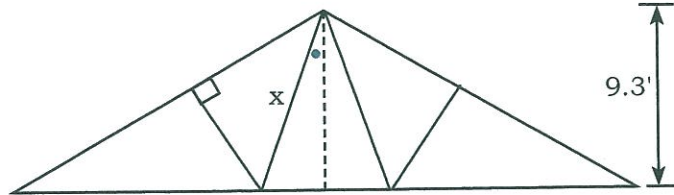

- 10) Eight holes are drilled evenly spaced in a piece of plywood with a 3 ft radius. Calculate the distance between the holes centre-to-centre.

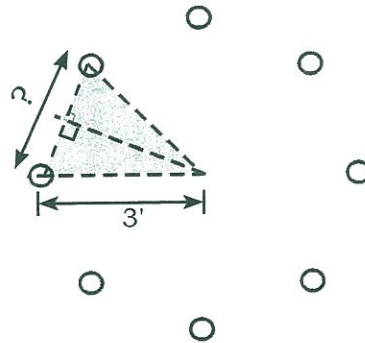

Hint:

Refer to Working with
Multi-sided Shapes
for help.

ANSWER KEY

GEOMETRY - RIGHT-ANGLE TRIANGLES

Page 202, **Angles**

- | | |
|------------------------------|---------------------------|
| 1) a) $\angle Y, \angle XYZ$ | b) $\angle 2, \angle Y$ |
| c) $\angle XZY, \angle Z$ | d) $\angle YXZ, \angle X$ |
| 2) a) 180° | b) 180° |
| c) 180° | d) 360° |

3) a)

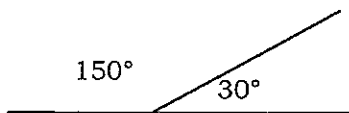

b)

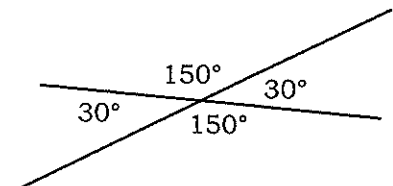

c)

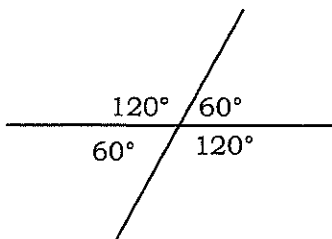

d)

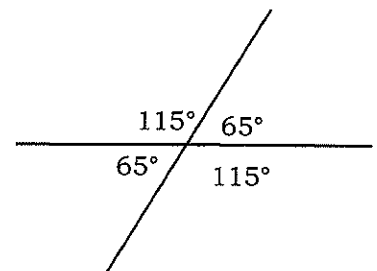

- | | |
|------------------|----------------|
| 4) a) 30° | b) 180° |
| c) 180° | d) 100° |
| e) 150° | f) 300° |

Page 204, **Calculating the Missing Angle in a Triangle**

- | | | |
|----------------|---------------|---------------|
| 1) 45° | 2) 60° | 3) 60° |
| 4) 20° | 5) 25° | 6) 20° |
| 7) 75° | 8) 33° | 9) 10° |
| 10) 64° | | |

Page 206, **Calculating Degrees, Minutes and Seconds**

- | | | | |
|----------------|--------------|--------------|--------------|
| 1) a) $1' 1''$ | b) $1' 59''$ | c) $1' 12''$ | d) $1' 52''$ |
| 2) a) $3'$ | b) $3' 3''$ | c) $1' 17''$ | d) $4' 2''$ |

Page 207, **Calculating Degrees, Minutes and Seconds**

- 1) a) $1^{\circ} 1'$ b) $1^{\circ} 59'$ c) $47'$ d) $1^{\circ} 20'$
2) a) $1^{\circ} 50'$ b) $1^{\circ} 35'$ c) $4^{\circ} 15'$ d) 1°

Page 208, **Adding Angles**

- 1) $42^{\circ} 51' 48''$ 2) $9^{\circ} 2' 50''$ 3) $76^{\circ} 33' 19''$ 4) $105^{\circ} 52' 11''$
5) 90° 6) $48^{\circ} 13' 11''$ 7) $76^{\circ} 59' 57''$ 8) $93^{\circ} 1' 33''$
9) $72^{\circ} 19' 0''$ 10) $34^{\circ} 42' 2''$ 11) $144^{\circ} 17' 33''$ 12) 180°
13) $248^{\circ} 40'$ 14) $80^{\circ} 1' 12''$ 15) 180° 16) $40^{\circ} 8' 1''$

Page 209, **Subtracting Angles**

- 1) $18^{\circ} 12' 26''$ 2) $22^{\circ} 59' 29''$ 3) $1^{\circ} 1' 11''$ 4) $33^{\circ} 13' 34''$
5) $12^{\circ} 15' 28''$ 6) $14^{\circ} 42' 5''$ 7) $0^{\circ} 1' 6''$ 8) $72^{\circ} 55' 52''$
9) $10^{\circ} 51' 59''$ 10) $68^{\circ} 17' 21''$ 11) $0^{\circ} 22' 1''$ 12) $18^{\circ} 12' 28''$
13) $11^{\circ} 57' 2''$ 14) $22^{\circ} 59' 59''$ 15) $8^{\circ} 48' 51''$ 16) $63^{\circ} 2' 0''$

Page 212, **Pythagorean Theorem**

- 1) $1.8^2 + 2.7^2 = \text{travel}^2$
 $\sqrt{10.53} = \text{travel}$
3.24 m = travel
- 2) $7^2 + 11^2 = \text{travel}^2$
 $\sqrt{170} = \text{travel}$
13.04 ft = travel
- 3) $15.3^2 - 2.5^2 = \text{run}$
 $\sqrt{227.84} = \text{run}$
15.09 m = run
- 4) $20^2 - 16^2 = \text{rise}$
 $\sqrt{144} = \text{rise}$
12 ft = rise
- 5) $62\,267^2 - 2\,900^2 = \text{rise}^2$
 $\sqrt{3\,868\,769\,289} = \text{rise}^2$
62\,199.43 mm = rise
- 6) $1\,000^2 + 2\,455^2 = \text{travel}^2$
 $\sqrt{7\,027\,025} = \text{travel}$
2\,650.85 mm = travel
- 7) $4\,236^2 + 1\,955^2 = \text{travel}^2$
 $\sqrt{21\,765\,721} = \text{travel}$
4\,665.37 mm = travel
 $4\,665.37 + 850 = 5\,515.37$ mm
- 8) $1\,829^2 + 1\,355^2 = \text{travel}^2$
 $\sqrt{5\,181\,266} = \text{travel}$
2\,276.24 mm = travel
 $2\,276.24 + 305 = 2\,581.24$ mm
- 9) $2\,400^2 + 1\,500^2 = \text{travel}^2$
 $\sqrt{8\,010\,000} = \text{travel}^2$
2\,830.19 mm = travel
 $2\,830.19 + 350 = 3\,180.19$ mm

10) $6\,875^2 + 3\,658^2 = \text{travel}^2$
 $\sqrt{60\,646\,589} = \text{travel}^2$
 $7\,787.59 = \text{travel}$
 $7\,787.59 + 875 = 8\,662.59 \text{ mm}$

Page 214, **Trigonometry**

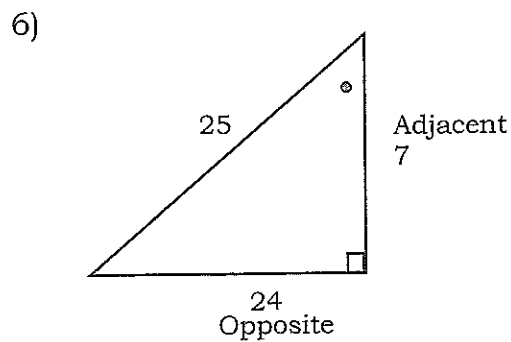
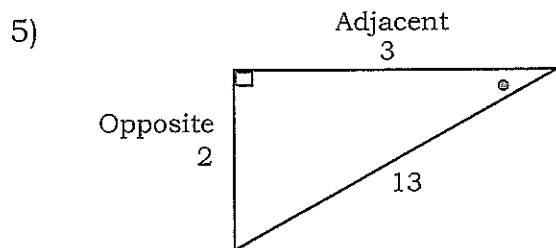
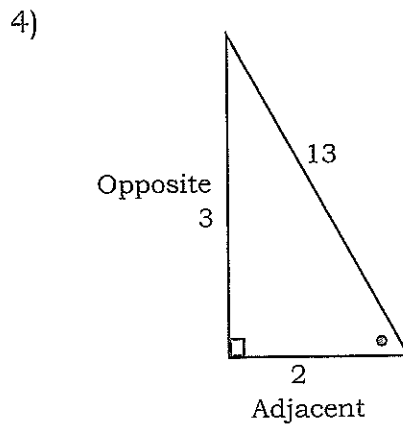
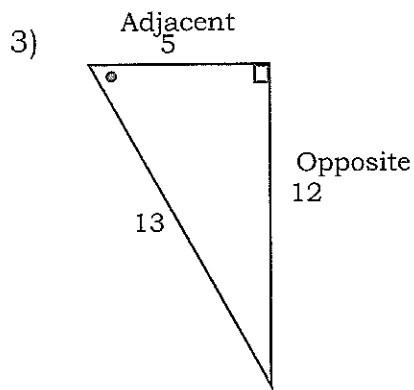
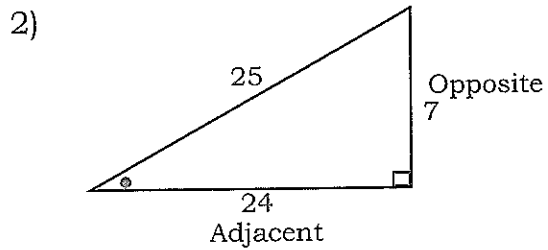
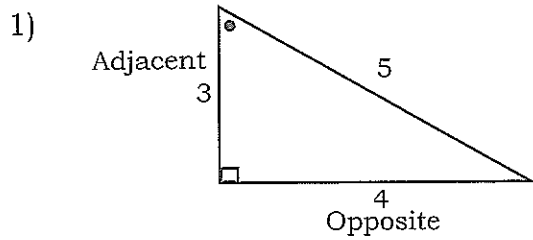

7)

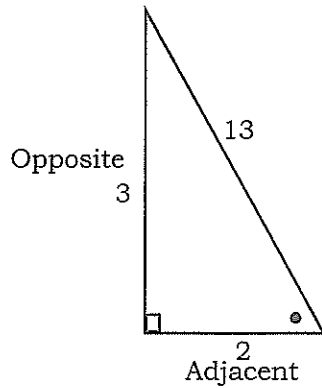

8)

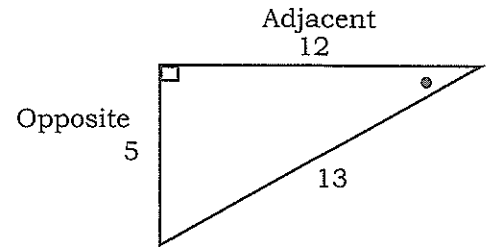

9)

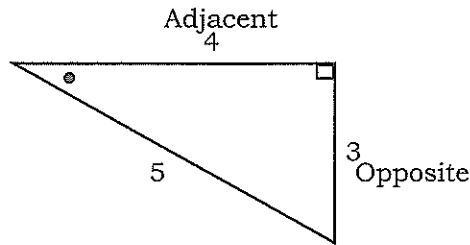

10)

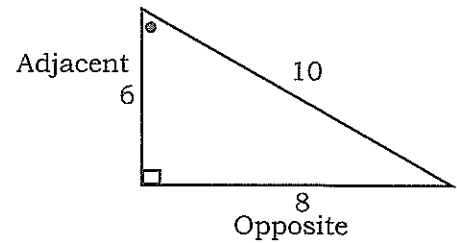

Page 218, **Calculating the Length of a Side**

- 1) $\text{hypotenuse} = \frac{\text{opposite}}{\sin} = \frac{3.1}{\sin 46^\circ} = 4.31 \text{ ft}$
- 2) $\text{hypotenuse} = \frac{\text{adjacent}}{\cos} = \frac{16}{\cos 50^\circ} = 24.89 \text{ cm}$
- 3) $\text{adjacent} = \cos \times \text{hypotenuse} = \cos 33^\circ \times 4.25 = 3.56 \text{ ft}$
- 4) $\text{opposite} = \tan \times \text{adjacent} = \tan 63^\circ \times 1.35 = 2.65 \text{ m}$
- 5) $\text{adjacent} = \cos \times \text{hypotenuse} = \cos 27^\circ \times 6.25 = 5.57 \text{ ft}$
- 6) $\text{hypotenuse} = \frac{\text{adjacent}}{\cos} = \frac{96}{\cos 71^\circ} = 294.87 \text{ in}$
- 7) $\text{opposite} = \tan \times \text{adjacent} = \tan 47^\circ \times 15 = 16.09 \text{ in}$
- 8) $\text{opposite} = \sin \times \text{hypotenuse} = \sin 37^\circ \times 4.3 = 2.59 \text{ m}$
- 9) $\text{hypotenuse} = \frac{\text{adjacent}}{\cos} = \frac{546}{\cos 42^\circ} = 734.72 \text{ cm}$
- 10) $\text{adjacent} = \frac{\text{opposite}}{\tan} = \frac{3.6}{\tan 65^\circ} = 1.68 \text{ ft}$

Page 222, **Calculating the Size of an Angle**

$$1) \quad \sin = \frac{\text{opposite}}{\text{hypotenuse}} = \frac{2.3}{6.4} = 0.0359375$$

Press 2nd function. Press sin. 21.06°

$$2) \quad \cos = \frac{\text{adjacent}}{\text{hypotenuse}} = \frac{150}{252} = 0.595238095$$

Press 2nd function. Press cos. 53.47°

$$3) \quad \cos = \frac{\text{adjacent}}{\text{hypotenuse}} = \frac{49}{69} = 0.710144928$$

Press 2nd function. Press cos. 44.75°

$$4) \quad \sin = \frac{\text{opposite}}{\text{hypotenuse}} = \frac{3.33}{5.25} = 0.634285714$$

Press 2nd function. Press sin. 39.37°

$$5) \quad \tan = \frac{\text{opposite}}{\text{adjacent}} = \frac{0.155}{1.24} = 0.125$$

Press 2nd function. Press tan. 7.13°

$$6) \quad \sin = \frac{\text{opposite}}{\text{hypotenuse}} = \frac{1.5}{4.17} = 0.35971223$$

Press 2nd function. Press sin. 21.08°

$$7) \quad \cos = \frac{\text{adjacent}}{\text{hypotenuse}} = \frac{2.5}{3.1} = 0.806451613$$

Press 2nd function. Press cos. 36.25°

$$8) \quad \sin = \frac{\text{opposite}}{\text{hypotenuse}} = \frac{15}{26.5} = 0.566037736$$

Press 2nd function. Press sin. 34.47°

$$9) \quad \tan = \frac{\text{opposite}}{\text{adjacent}} = \frac{2.42}{3.42} = 0.707602339$$

Press 2nd function. Press tan. 35.28°

$$10) \quad \sin = \frac{\text{opposite}}{\text{hypotenuse}} = \frac{1.78}{5.46} = 0.326007326$$

Press 2nd function. Press sin. 19.03°

Page 226, **Working with Multi-sided Shapes**

- 1) angle A = $360 \div 12 = 30^\circ$
 angle B = $90 - 30 = 60^\circ$
 side a = $\tan \times \text{adjacent} = \tan 30^\circ \times 20 = 11.55 \text{ ft}$
 side c = $\frac{\text{adjacent}}{\cos} = \frac{20}{\cos 30^\circ} = 23.1 \text{ ft}$
- 2) angle A = $360 \div 14 = 25.71^\circ$
 angle B = $90 - 25.71 = 64.29^\circ$
 side a = $\sin \times \text{hypotenuse} = \sin 25.71^\circ \times 24 = 10.41 \text{ ft}$
 side b = $\cos \times \text{hypotenuse} = \cos 25.71^\circ \times 24 = 21.62 \text{ ft}$
- 3) angle A = $360 \div 16 = 22.5^\circ$
 angle B = $90 - 22.5 = 67.5^\circ$
 side b = $\frac{\text{opposite}}{\tan} = \frac{8}{\tan 22.5^\circ} = 19.31 \text{ m}$
 side c = $\frac{\text{opposite}}{\sin} = \frac{8}{\sin 22.5^\circ} = 20.91 \text{ m}$

Page 226, **Practice**

- 1) $a^2 + b^2 = c^2$
 $5^2 + 12^2 = c^2$
 $169 = c^2$
 $\sqrt{169} = c$
 $13 = c$
 The diagonal should measure 13 ft.
- 2) $a^2 + b^2 = c^2$
 $8^2 + 15^2 = c^2$
 $289 = c^2$
 $\sqrt{289} = c$
 $17 = c$
 The length of the brace is 17 feet.
- 3) $c^2 - a^2 = b^2$
 $6.5^2 - 6^2 = b^2$
 $6.25 = b^2$
 $\sqrt{6.25} = b$
 $2.5 = b$
 The brace must be secured 2.5 m from the wall.

- 4) $a^2 + b^2 = c^2$
 $9.2^2 + 5.6^2 = c^2$
 $116 = c^2$
 $\sqrt{116} = c$
 $10.77 = c$
 The diagonal length of the staircase is 10.77 ft.
- 5) $a^2 + b^2 = c^2$
 $8^2 + 9.2^2 = c^2$
 $148.64 = c^2$
 $\sqrt{148.64} = c$
 $12.19 = c$
 $12.19 + 3 = 15.19$
 The length of the rafter needs to be 15.19 ft.
- 6) $c^2 - a^2 = b^2$
 $71.1^2 - 46.6^2 = b^2$
 $2\ 883.65 = b^2$
 $\sqrt{2\ 883.65} = b$
 $53.70 = b$
 The length of the lot is 53.70 ft.
- 7) $\text{hypotenuse} = \frac{\text{opposite}}{\sin} = \frac{15}{\sin 75^\circ} = 15.5 \text{ ft}$
 $15.5 + 3 = 18.5 \text{ feet}$
 The ladder needs to be at least 18.53 feet long.
- 8) $\text{hypotenuse} = \frac{\text{opposite}}{\sin} = \frac{6.33}{\sin 40^\circ} = 9.85 \text{ ft}$
 The length of the rafter is 9.85 ft.
- 9) $x = \frac{\text{adjacent}}{\cos} = \frac{9.3}{\cos 25^\circ} = 10.26 \text{ ft}$
- 10) $\text{angle A} = 360^\circ \div 16 = 22.5^\circ$
 $\text{opposite} = \tan \times \text{adjacent} = \tan 22.5^\circ \times 3 = 1.24 \text{ ft}$
 $1.24 \times 2 = 2.48 \text{ ft}$
 The distance between holes centre-to-centre is 2.30 feet.